

The logo for GemLock features a stylized orange and white icon on the left, resembling a fire hydrant or a fire alarm bell. To its right, the word "GemLock" is written in a bold, sans-serif font. "Gem" is in white, and "Lock" is in orange. A registered trademark symbol (®) is located at the top right of the letter "k".

GemLock[®]

Complete Grooved System for All Your Fire Protection Needs



TABLE OF CONTENTS

Grooved Piping System.....	2
GemLock® Features.....	3
Rigid Coupling - Style 5	4
Rigid Coupling Angle Pattern - Style 5A.....	5
One-Bolt, Push-on Coupling - Style 99.....	6
Two-Bolt, Angle Pattern Push-on Coupling - Style 99-2	7
Flexible Coupling - Style 12.....	8
Reducing Coupling - Style 25	9
Flange Adapter - Style F190.....	10
Grooved Flange - Style 14	11
Flange Adapter Insert - Style 20.....	12
Mechanical Tee Grooved - Style 15.....	13
Mechanical Tee Grooved - Style 35.....	14
Mechanical Tee Threaded - Style 16.....	15
Mechanical Tee Threaded - Style 36.....	16
Tee Lock - Style 13.....	17
Tee Lock - Style 13A.....	18
Grooved Fittings - Short Pattern - Styles F105, F106, F107, F135.....	19
Standard Grooved Fittings - Styles 100, 101, 102, 103, 110, & 150	20
Reducing Tee - Short Pattern - Style 115.....	21
Standard Reducer - Style 140 Concentric - Style 145 Eccentric.....	22
Standard Drain Elbow - Style F100D & Drain Tee - Style 115D	23
Standard Drain Cap - Style F155D	24
90° Adapter Ell - Style 105TL.....	25
Lansdale® Grooved End Swing Check Valve - Model LVCVGG-400.....	26
Lansdale® Grooved End Check Valve w/Inspection Cover - Model LVCVGG-RF	27
Lansdale® Riser Check Assembly (Shot Gun Riser) - Model LVRCGG	28
Lansdale® Wafer Butterfly Valve with Tamper - Model LVWBG	29
Lansdale® Powerball 300 Sprinkler Control Valve - Models LPBT & LPBG	30
Lansdale® Grooved Butterfly Valve - Model LVBG1 & LVBG3	31
Lansdale® Lever Handle Grooved Butterfly Valve - Model LV-GTV.....	32
PI Tape Instructions.....	33
Pipe Preparation/Pipe Grooving Specifications	34
Rigid Coupling - Style 5 & Flexible Coupling - Style 12 Installation Instructions	35
Rigid Coupling - Style 5A Angle Pattern Installation Instructions.....	36
One-Bolt, Push-on Coupling - Style 99 Installation Instructions.....	37
Two-Bolt, Angle Pattern Push-on Coupling - Style 99-2 Installation Instructions	38
Grooved Flange - Style 14 Installation Instructions	39
Mechanical Tee Installation Instructions.....	40
Gasket Data.....	41
Cross Reference Chart.....	42
Terms and Conditions.....	43

GemLock is reliable and faster to install than welding, threading or flanging, resulting in lower installation cost. Triple sealing of the C-shaped pressure responsive gasket is made from specially compounded rubber polymers with low compression set properties. Couplings perform equally well under pressure and vacuum. Couplings are available for flexible and rigid systems, and are all pre-lubricated.

HOUSINGS

Ductile iron housing segments conforming to ASTM-A536 Grade 65-45-12 which fully enclose the gasket. The housing keys engage into the grooves around the full pipe circumference, securing the pipe ends together with a positive grip. The housing is designed to provide the optimum combination of pressure, stress relief and end load conditions while maintaining reasonable weight and manufacturing characteristics. Every grooved pipe coupling, flange adapter and reducing coupling has a similar key section. This engages fully into the groove tying the joint integrally to the pipe.

GASKETS

The sealing efficiency of gaskets is such that the gasket forms an initial seal as it is stretched over the pipe ends. As the housing segments are installed and secured the pressure responsive gasket is slightly compressed to form a leak-tight joint. The strength of the seal is further enhanced by internal line pressure that creates downward pressure on the lips of the gasket. The gasket also seals well under vacuum conditions up to 10 in Hg (-0.35 Bar) which may occur when a system is drained. Please refer to the gasket selection guide for additional details and gasket materials. Gaskets are pre-lubricated for easy assembly of the coupling but should be lightly lubed for further ease of assembly and performance.

ROLL OR CUT GROOVED STANDARD STEEL PIPE

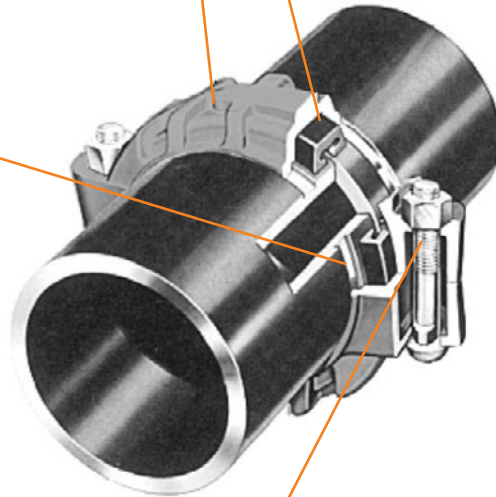

BOLTS AND NUTS

Oval neck track bolt conforming to ASTM A183 with minimum tensile strength of 110,000 psi or square neck carriage bolt to ASTM A446 with 120,000 psi minimum tensile strength permits tightening of the nuts from one side with a single wrench. Nuts conform to ASTM A194. Bolts and nuts are electro galvanized.

FEATURES

REDUCED COST



Coupling assembly is quick and easy. Minimal training required. The system is free from contaminants such as weld slag and pipe dope. Installation costs are controllable and estimates are more precise.

UNION TYPE JOINT

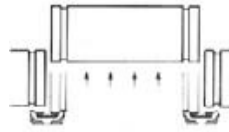

Coupling can be disassembled easily permitting maintenance and servicing of the piping system. It will facilitate periodic rotation of pipe to distribute internal wear from slurries or other abrasive media.

RELIABILITY

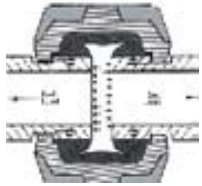

The coupling engages the pipe around the entire circumference and restrains the pipe ends from separation due to pressure and other forces, up to the maximum coupling rated working pressure.

RIGID COUPLINGS

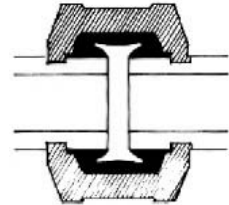

Rigid couplings, both standard and slip-on design are available to supply a rigid, “weld-like” connection where required. These couplings are primarily used in fire protection systems, as well as when connecting piping appurtenances such as valves, strainers etc.

EXPANSION AND CONTRACTION

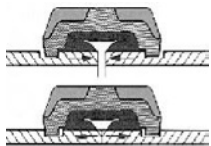

Flexible Coupling provides linear movement at each joint. Allows pipe expansion and contraction. Suitable for hot and cold water lines and dual temperature systems.

DEFLECTION AND MISALIGNMENT

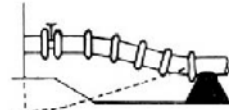

Precise location of pipe openings through walls and floors is unnecessary. Long radius curves may be designed with fewer elbows. Useful for providing pitch for drainage. Facilitates laying pipe on rough or uneven terrain, when using flexible couplings.

NOISE AND VIBRATION

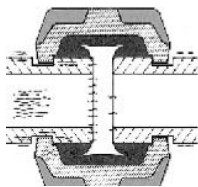

Slight gap between pipe ends isolates noise and vibration. Resilient gasket also helps to absorb noise and vibration. Often permits elimination of noise suppression devices.

STRESS FREE JOINT - FLEXIBLE COUPLINGS

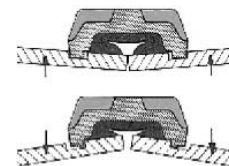

Flexibility of the joint reduces or eliminates stresses from settlement of buried pipe or induced by seismic tremors.

RIGID COUPLING STYLE 5



- **Housing:** Ductile Iron conforming to ASTM A536, Grade 65-45-12
- **Bolts/Nuts:** Zinc electroplated carbon steel oval neck track head bolts conforming to ASTM A183 Grade 2 and SAE J429 Grade 5 with a minimum tensile strength of 110,000 psi. Zinc electroplated carbon steel heavy hex nut conforming to ASTM A536, Grade A.
- **Coatings:** Rust inhibiting orange paint (Standard) or Hot Dipped Galvanized (Optional) conforming to ASTM A153
- **Gasket Material:** Pre-Lubricated Grade “E” EPDM, Approved and Listed for use in Wet or Dry Systems
- **Gasket Temperature Range:** -40°F to 230°F (Service temperature range)
- **Lubrication:** Supplemental lubricant is recommended for services below 0°F and for all dry pipe systems or systems to be subjected to air tests prior to being filled with water.
- **Sizes:** 1” to 12”
- **Maximum Working Pressure:** 300 psi

Available with a GemSeal EPDM gasket specifically designed for use in a dry fire sprinkler piping system, and will prohibit the build-up of contaminants within the gasket cavity if used in other types of piping systems. This gasket has a centering rib that fits over the pipe ends, closing off the gasket cavity.

The Style 5 Coupling is our standard coupling and is designed for joint rigidity, providing a “weld like joint”. Conforms to the requirements of ANSI B31.1 Power Piping Code; ANSI B31.9 Building Service Pipe Code and NFPA13 sprinkler systems.

Before installing, please read the Installation Instructions on page 35.

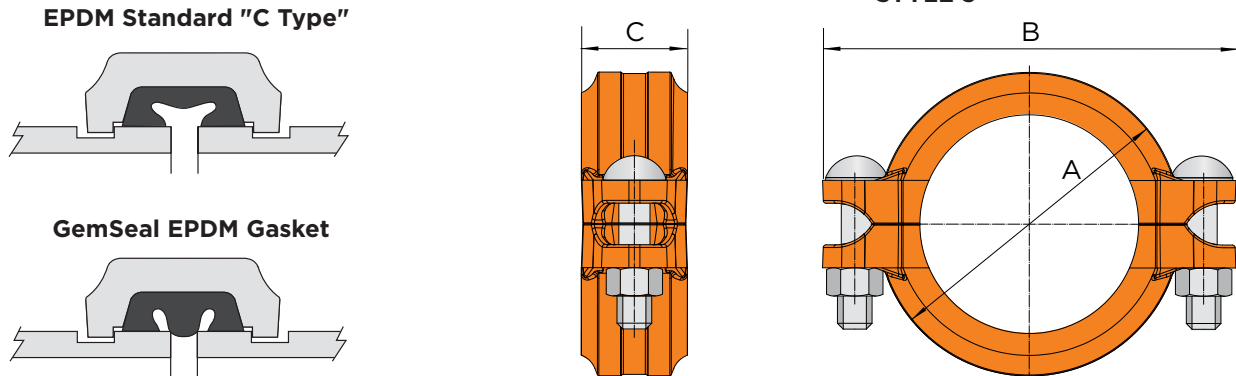

RIGID COUPLING STYLE 5								
Pipe		Max. Working Pressure (psi)*	Allow Pipe End Separation (in.)	Dimensions (in.)			Bolt Size (in.)	Approx. Weight Each (lb.)
Nominal Size (in.)	Actual Size (in.)			A	B	C		
1	1.315	300	0.1	2.36	4.02	1.77	3/8 x 1-3/4	1.2
1-1/4	1.66	300	0.1	2.76	4.17	1.73	3/8 x 1-3/4	1.31
1-1/2	1.9	300	0.1	2.87	4.25	1.73	3/8 x 1-3/4	1.26
2	2.375	300	0.1	3.43	4.84	1.73	3/8 x 2-3/16	1.47
2-1/2	2.875	300	0.1	3.94	5.43	1.73	3/8 x 2-3/16	1.76
3	3.5	300	0.1	4.61	6.54	1.77	1/2 x 2-3/8	2.41
4	4.5	300	0.16	5.47	7.48	1.93	1/2 x 2-1/2	2.93
5	5.563	300	0.16	6.58	8.62	1.93	1/2 x 3	3.55
6	6.625	300	0.16	7.82	9.80	1.97	1/2 x 3	4.73
8	8.625	300	0.19	9.96	12.60	2.32	7/8 x 4-3/4	8.15
10	10.75	300	0.19	13.19	16.77	2.56	7/8 x 5-1/8	17.08
12	12.75	300	0.20	14.96	18.50	2.60	7/8 x 5-1/8	24.5

RIGID COUPLING - ANGLE PATTERN STYLE 5A



- **Housing:** Ductile Iron conforming to ASTM A536, Grade 65-45-12
- **Bolts/Nuts:** Zinc electroplated carbon steel oval neck track head bolts conforming to ASTM A183 Grade 2 and SAE J429 Grade 5 with a minimum tensile strength of 110,000 psi. Zinc electroplated carbon steel heavy hex nut conforming to ASTM A536, Grade A.
- **Coatings:** Rust inhibiting orange paint (Standard) or Hot Dipped Galvanized (Optional) conforming to ASTM A153
- **Gasket Material:** Pre-Lubricated Grade “E” EPDM, Approved and Listed for use in Wet or Dry Systems
- **Gasket Temperature Range:** -40°F to 230°F (Service temperature range)
- **Lubrication:** Supplemental lubricant is recommended for services below 0°F and for all dry pipe systems or systems to be subjected to air tests prior to being filled with water.
- **Sizes:** 1” to 12”
- **Maximum Working Pressure:** 300 psi

The Style 5A Coupling is our standard coupling and is designed for joint rigidity, providing a “weld like joint”. Conforms to the requirements ANSI B31.1 Power Piping Code; ANSI B31.9 Building Service Pipe Code and NFPA13 sprinkler systems.

Before installing, please read the Installation Instructions on page 36.

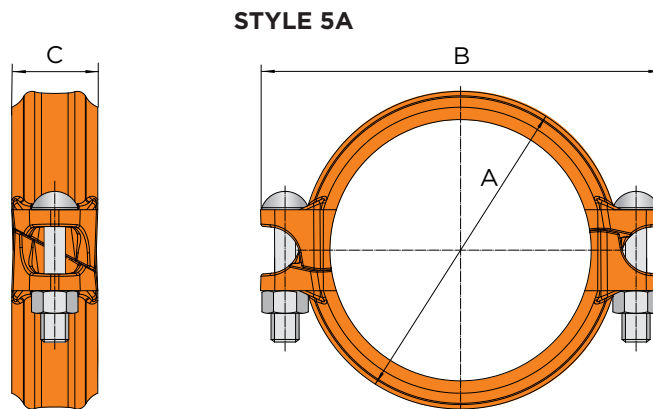

RIGID COUPLING - ANGLE PATTERN STYLE 5A							
Pipe		Max. Working Pressure (psi)*	Dimensions (in.)			Bolt Size (in.)	Approx. Weight Each (lb.)
Nominal Size (in.)	Actual Size (in.)		A	B	C		
1-1/4	1.66	300	2.60	4.17	1.85	3/8 x 2-3/16	1.31
1-1/2	1.90	300	2.78	4.37	1.85	3/8 x 2-3/16	1.20
2	2.375	300	3.35	4.86	1.85	3/8 x 2-3/8	1.47
2-1/2	2.875	300	3.90	5.41	1.85	3/8 x 2-3/8	1.67
3	3.50	300	4.61	6.48	1.87	1/2 x 2-1/2	2.42
4	4.50	300	5.53	7.40	2.05	1/2 x 2-3/4	2.93
5	5.563	300	6.60	8.62	2.05	1/2 x 2-3/4	4.40
6	6.625	300	7.60	9.57	2.07	1/2 x 2-3/4	4.73
8	8.625	300	9.88	12.60	2.52	5/8 x 4-3/8	8.23
10	10.75	300	12.44	15.75	2.60	7/8 x 6-1/8	17.04
12	12.75	300	14.82	18.27	2.60	1 x 6-1/2	21.87

ONE-BOLT PUSH-ON COUPLING STYLE 99



- **Housing:** Ductile Iron conforming to ASTM A536, Grade 65-45-12
- **Bolts/Nuts:** Zinc electroplated carbon steel oval neck track head bolts conforming to ASTM A183 Grade 2 and SAE J429 Grade 5 with a minimum tensile strength of 110,000 psi. Zinc electroplated carbon steel heavy hex nut conforming to ASTM A536, Grade A.
- **Coatings:** Rust inhibiting orange paint (Standard) or Hot Dipped Galvanized (Optional) conforming to ASTM A153
- **Gasket Material:** Pre-Lubricated Grade “E” EPDM, Approved and Listed for use in Wet or Dry Systems
- **Gasket Temperature Range:** -40°F to 230°F (Service temperature range)
- **Lubrication:** Supplemental lubricant is recommended for services below 0°F and for all dry pipe systems or systems to be subjected to air tests prior to being filled with water.
- **Sizes:** 1” to 6”
- **Maximum Working Pressure:** Schedule 10/40 365 psi, Schedule 7 300 psi

The Style 99 Push-On Coupling is an advanced rigid grooved coupling designed to connect grooved joints (whether rolled or cut) to standard grooved specifications for steel pipes. This innovative coupling utilizes two ductile iron housings that lock together with a single bolt, eliminating the need to disassemble the coupling for installation (refer to the next page for installation instructions).

This design significantly speeds up the installation process, resulting in a more economical solution for joining grooved piping and reducing overall installation costs for any grooved piping project.

Before installing, please read the Installation Instructions on page 37.

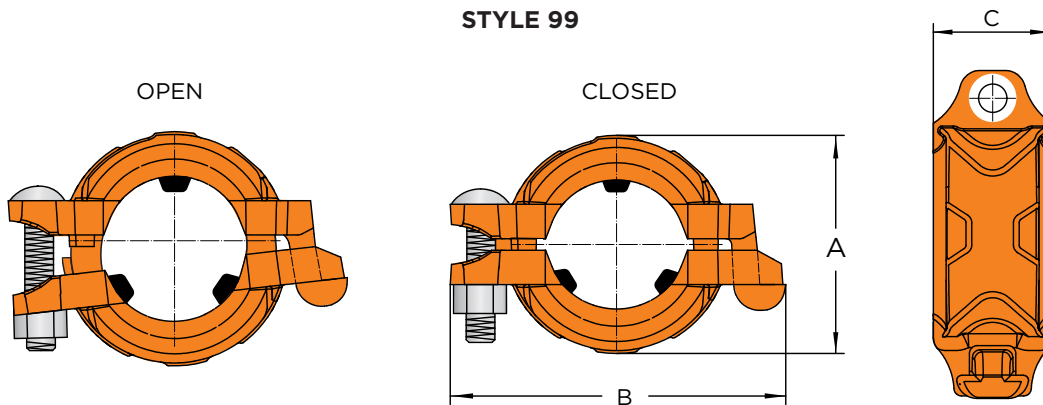

ONE-BOLT, PUSH-ON COUPLING STYLE 99						
Nominal Size (in.)	Pipe O.D. (in.)	Dimensions L (in.)			Bolt Size (in.)	Weight (lbs.)
		A	B	C		
1	1.32	2.35	4.0	1.81	3/8 x 2-3/16	1.18
1-1/4	1.67	2.68	4.34	1.81	3/8 x 2-3/8	1.24
1-1/2	1.9	3.0	4.60	1.81	3/8 x 2-3/8	1.30
2	2.37	3.50	5.08	1.81	3/8 x 2-1/2	1.52
2-1/2	2.87	3.84	5.55	1.81	3/8 x 2-3/4	1.87
3	3.5	4.47	6.61	1.81	1/2 x 3-1/8	2.27
4	4.5	5.60	7.72	1.89	1/2 x 3-1/8	3.09
5	5.56	6.75	9.02	2.03	1/2 x 3-3/8	3.55
6	6.63	8.03	10.24	2.17	1/2 x 3-1/2	5.28

TWO-BOLT ANGLE PATTERN PUSH-ON COUPLING

STYLE 99-2



- **Housing:** Ductile Iron conforming to ASTM A536, Grade 65-45-12
- **Bolts/Nuts:** Zinc electroplated carbon steel oval neck track head bolts conforming to ASTM A183 Grade 2 and SAE J429 Grade 5 with a minimum tensile strength of 110,000 psi. Zinc electroplated carbon steel heavy hex nut conforming to ASTM A536, Grade A.
- **Coatings:** Rust inhibiting orange paint (Standard) or Hot Dipped Galvanized (Optional) conforming to ASTM A153
- **Gasket Material:** Pre-Lubricated EPDM, when installed the center stop of the gasket offers the same performance characteristics as a GemSeal gasket which is often required for dry systems. Gasket Approved and Listed for use in Wet or Dry Systems
- **Gasket Temperature Range:** -40°F to 230°F (Service temperature range)
- **Lubrication:** Supplemental lubrication is recommended for services below 0°F and for all dry pipe systems, or systems that will be subjected to an air test prior to being filled with water.
- **Sizes:** 1" to 8"
- **Maximum Working Pressure:** 300 psi

The Style 99-2, Two-Bolt Angle Pattern Push-On Rigid Coupling, is an advanced grooved coupling designed to connect grooved joints (whether rolled or cut) to standard grooved specifications for steel pipes. This innovative coupling utilizes two ductile iron housings that lock together, eliminating the need to disassemble the coupling for installation

This design significantly speeds up the installation process, resulting in a more economical solution for joining grooved piping and reducing overall installation costs for any grooved piping project.

Before installing, please read the Installation Instructions on page 38.

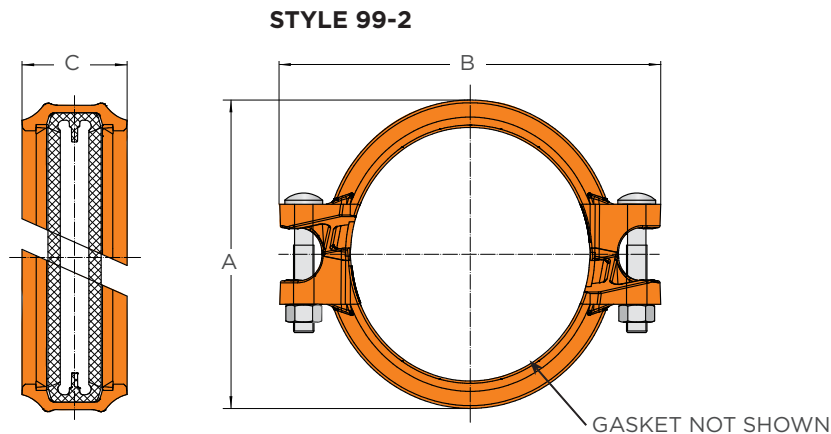

TWO-BOLT ANGLE PATTERN, PUSH-ON COUPLING STYLE 99-2						
Nominal Size (in.)	Pipe O.D. (in.)	Dimensions (in.)			Bolt Size (in.)	Weight (lbs.)
		A	B	C		
1	1.32	2.48	3.74	1.85	3/8 x 2-3/16	1.19
1-1/4	1.67	2.83	4.09	1.85	3/8 x 2-3/16	1.25
1-1/2	1.9	3.03	4.37	1.85	3/8 x 2-3/16	1.30
2	2.37	3.58	4.84	1.85	3/8 x 2-3/16	1.56
2-1/2	2.87	4.06	5.39	1.85	3/8 x 2-3/8	1.80
3	3.5	4.69	6.10	1.91	3/8 x 2-3/8	2.16
4	4.5	5.87	7.28	2.03	1/2 x 2-1/2	2.97
5	5.56	7.01	8.46	2.05	1/2 x 3	3.92
6	6.63	8.07	9.61	2.07	1/2 x 3-1/8	4.55
8	8.63	10.39	12.44	2.52	5/8 X 4	8.89

FLEXIBLE COUPLING

STYLE 12

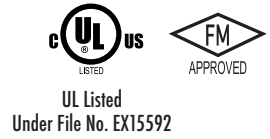

- **Housing:** Ductile Iron conforming to ASTM A536, Grade 65-45-12
- **Bolts/Nuts:** Zinc electroplated carbon steel oval neck track head bolts conforming to ASTM A183 Grade 2 and SAE J429 Grade 5 with a minimum tensile strength of 110,000 psi. Zinc electroplated carbon steel heavy hex nut conforming to ASTM A536, Grade A.
- **Coatings:** Rust inhibiting orange paint (Standard) or Hot Dipped Galvanized (Optional) conforming to ASTM A153
- **Gasket Material:** Pre-Lubricated Grade “E” EPDM, Approved and Listed for use in Wet or Dry Systems
- **Gasket Temperature:** Range: -40°F to 230°F (Service temperature range)
- **Lubrication:** Supplemental lubricant is recommended for services below 0°F and for all dry pipe systems or systems to be subjected to air tests prior to being filled with water.
- **Sizes:** 1” to 12”
- **Maximum Working Pressure:** 300 psi

The Style 12 Coupling is our flexible lightweight coupling designed for fire protection services. Conforms to the requirements ANSI B31.1 Power Piping Code; ANSI B31.9 Building Service Pipe Code and NFPA13 sprinkler systems.

Before installing, please read the Installation Instructions on page 35.

STYLE 12

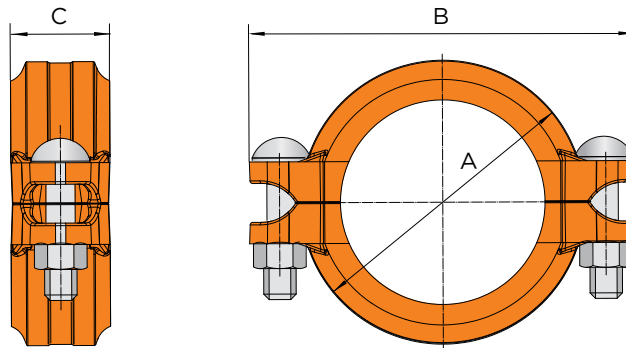

FLEXIBLE COUPLING STYLE 12

Pipe		Max. Working Pressure (psi)*	Allow Pipe End Separation (in.)	Max Deflection from Center Line	Dimensions (in.)			Bolt Size	Approx. Weight Each (lb.)	
Nominal Size (in.)	Actual Size (in.)				A	B	C			
1	1.315	300	0.1	5°-26'	1.14	2.36	3.86	1.71	3/8 x 1-3/4	1.2
1-1/4	1.66	300	0.1	4°-19'	0.9	2.63	4.17	1.732	3/8 x 1-3/4	1.30
1-1/2	1.9	300	0.1	3°-46'	0.79	2.87	4.25	1.732	3/8 x 1-3/4	1.27
2	2.375	300	0.1	3°-1'	0.62	3.43	4.84	1.732	3/8 x 2-3/16	1.48
2-1/2	2.875	300	0.1	2°-29'	0.52	3.94	5.43	1.732	3/8 x 2-3/16	1.71
3	3.5	300	0.1	2°-3'	0.43	4.61	6.35	1.77	1/2 x 2-3/8	2.44
4	4.5	300	0.16	3°-11'	0.67	5.47	7.48	1.929	1/2 x 2-1/2	2.89
5	5.563	300	0.16	2°-35'	0.54	6.61	8.58	1.929	1/2 x 3	3.58
6	6.625	300	0.16	2°-10'	0.46	7.82	9.49	1.929	1/2 x 3	4.73
8	8.625	300	0.19	1°-40'	0.34	9.96	12.60	2.323	1/2 x 3-3/8	7.91
10	10.75	300	0.19	0°-95'	0.13	12.48	15.79	2.48	7/8 x 5-1/8	16.95
12	12.75	300	0.20	0°-23'	0.12	14.76	17.91	2.52	7/8 x 5-1/8	24.0

REDUCING COUPLING

STYLE 25



UL Listed
Under File No. EX15592

- **Housing:** Ductile Iron conforming to ASTM A536, Grade 65-45-12
- **Bolts/Nuts:** Zinc electroplated carbon steel oval neck track head bolts conforming to ASTM A183 Grade 2 and SAE J429 Grade 5 with a minimum tensile strength of 110,000 psi. Zinc electroplated carbon steel heavy hex nut conforming to ASTM A536, Grade A.
- **Coatings:** Rust inhibiting orange paint (Standard) or Hot Dipped galvanized (Optional) conforming to ASTM A153
- **Gasket Material:** Pre-Lubricated Grade “E” EPDM, Approved and Listed for use in Wet or Dry Systems
- **Gasket Temperature Range:** -40°F to 230°F (Service temperature range)
- **Lubrication:** Supplemental lubricant is recommended for services below 0°F and for all dry pipe systems or systems to be subjected to air tests prior to being filled with water.
- **Sizes:** 1-1/2” to 8”
- **Maximum Working Pressure:** 300 psi

The Style 25 Reducing Coupling allows for direct connection of two different pipe sizes, eliminating the need for two couplings and a concentric reducer. The steel washer prevents telescoping of the smaller pipe inside the larger pipe during vertical system assembly.

STYLE 25

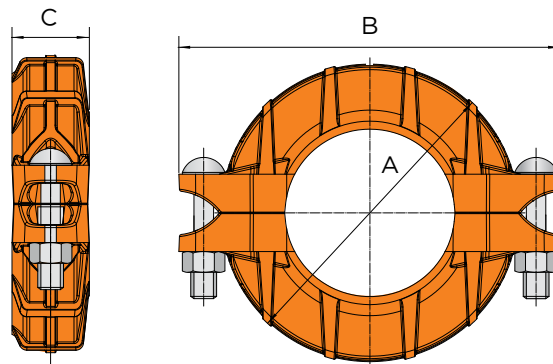

REDUCED COUPLING STYLE 25

Pipe Nominal Size (in.)	Max. Working Pressure (psi)	Allow Pipe End Separation (in.)	Max. Deduction from Center Line		Dimensions (in.)			Bolts No./ Size	Approx. Weight Each (lb.)
			Per Coup Deg.	Pipe (in.)	A	B	C		
1-1/2 x 1-1/4	300	0.12	1°-53'	0.4	2.88	4.55	1.77	2-3/8 x 1-3/4	1.75
2 x 1-1/2	300	0.12	1°-33'	0.4	3.543	5.079	1.85	2-3/8 x 2-3/16	1.95
2-1/2 x 2	300	0.12	1°-33'	0.32	3.976	5.394	1.8	2-3/8 x 2-3/16	2.50
3 x 2	300	0.12	1°-17'	0.26	4.724	6.45	1.89	2-1/2 x 2-1/2	3.64
3 x 2-1/2	300	0.12	1°-17'	0.26	4.72	6.457	1.89	2-1/2 x 2-1/2	3.27
4 x 2	300	0.25	2°-38'	0.55	5.906	7.677	1.929	2-1/2 x 2-1/2	4.74
4 x 2-1/2	300	0.25	2°-38'	0.55	5.906	7.677	1.929	2-1/2 x 2-1/2	4.55
4 x 3	300	0.25	2°-38'	0.55	5.906	7.677	1.929	2-1/2 x 2-1/2	4.16
5 x 4	300	0.25	2°-5'	0.44	6.969	8.74	1.909	2-5/8 x 3-1/2	6.65
6 x 4	300	0.25	1°-44'	0.38	7.992	9.252	1.969	2-1/2 x 3	8.16
8 x 6	300	0.25	1°-15'	0.26	10.394	12.32	2.362	2-5/8 x 4	15.15

FLANGE ADAPTERS

STYLE F190

- Conforms to ANSI Class 125 lb. flange/ASTM CL 150
- Available with an external threaded or grooved end
- Made of durable, high-strength ductile iron conforming to ASTM A536, Gr 65-45-12; every lot is metallurgically tested for compliance
- Available with Hot Dipped galvanized coating for corrosive environments
- Rated for 300 psi



STYLE F190

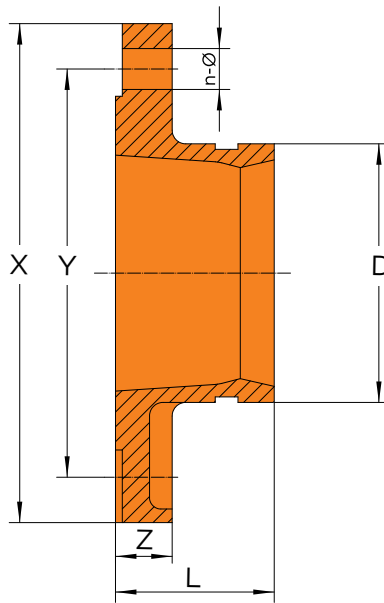

FLANGE ADAPTER - STYLE F190							
Nominal Size (in.)	Pipe OD D (in.)	Working Pressure (psi)	L (in.)	X (in.)	Y (in.)	Z (in.)	Bolt Size (in.) No. - Size
2	2.375	300	2.56	5.98	4.74	0.63	4-5/8
2-1/2	2.875	300	2.56	7.00	5.69	0.69	4-5/8
3	3.500	300	2.56	7.48	6.00	0.75	4-5/8
4	4.500	300	2.76	9.02	7.50	0.96	8-5/8
5	5.562	300	2.76	10.00	8.50	0.96	8-3/4
6	6.625	300	2.76	10.98	9.50	1.10	8-3/4
8	8.625	300	3.23	13.50	11.75	1.11	8-3/4
10	10.750	300	3.35	15.98	14.25	1.18	12-7/8
12	12.750	300	3.54	19.01	17.00	1.26	12-7/8

GROOVED FLANGE ADAPTER STYLE 14



UL Listed
Under File No. EX15592

- **Housing:** Ductile Iron conforming to ASTM A536, Grade 65-45-12
- **Bolts/Nuts:** Zinc electroplated carbon steel oval neck track head bolts conforming to ASTM A183 Grade 2 and SAE J429 Grade 5 with a minimum tensile strength of 10,000 psi. Zinc electroplated carbon steel heavy hex nut conforming to ASTM A536, Grade A.
- **Coatings:** Rust inhibiting orange paint (Standard) or Hot Dipped Galvanized (Optional) conforming to ASTM A153
- **Gasket Material:** Pre-Lubricated Grade “E” EPDM, Approved and Listed for use in Wet or Dry Systems
- **Size:** 2” to 12”
- **Maximum Working Pressure:** 2” to 8” 300 psi, 10” & 12” 175 psi

The Style 14 Flange is designed to connect ANSI Class 125 or Class 150 flange components to grooved piping systems. The use of a Style 20 Gemlock® Steel Adapter is required when used against rubber faced surfaces, serrated or irregular sealing surfaces.

Before installing, please read the Installation Instructions on page 39.

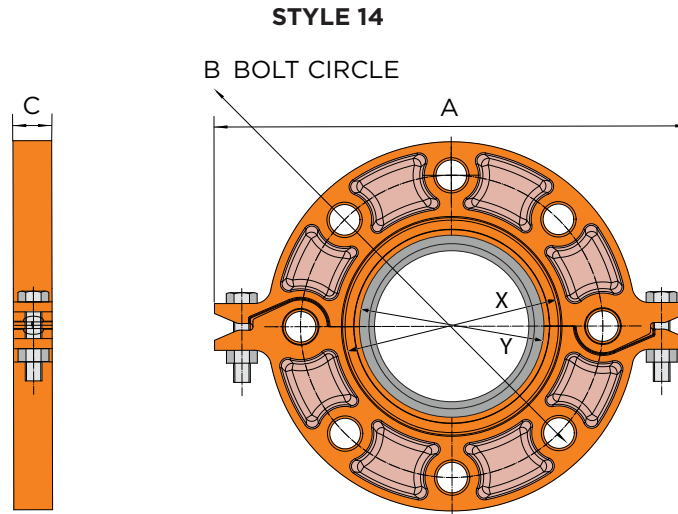

GROOVED FLANGE STYLE 14									
Pipe		Max Working Pressure (psi) *	Sealing Surface (in.)		Dimensions (in.)			Bolts	Approx. Weight Each (lb.)
Nominal Size (in.)	Actual Size (in.)		X Min	Y Max.	A	B (Bolt Circle)	C	No./Size	
2	2.375	300	3.09	2.42	8.11	4.763	0.866	4-5/8 x 2-3/4	3.84
2-1/2	2.875	300	3.58	2.92	9.055	5.511	0.866	4-5/8 x 2-3/4	5.08
3	3.5	300	4.21	3.56	9.527	5.984	0.944	4-5/8 x 2-3/4	5.17
4	4.5	300	5.26	4.57	11.023	7.519	0.944	8-5/8 x 2-3/4	6.46
5	5.563	300	6.41	5.65	12.795	8.503	0.964	8-3/4 x 2-7/8	8.64
6	6.625	300	7.48	6.71	13.583	9.5	0.964	8-3/4 x 3-1/8	8.49
8	8.625	300	9.58	8.7	16.311	11.751	1.102	8-3/4 x 3-1/4	13.48
10	10.75	175	11.65	10.85	20	14.25	1.195	12-7/8 x 3-1/2	24.0
12	12.75	175	13.60	12.90	20.25	17.0	1.25	12-7/8 x 4	38.0

FLANGE ADAPTER INSERT

STYLE 20

The GemLock®, “Flange Seal Ring Adapter” is designed to be used with the GemLock® Style 14, Grooved Flange. This flange ring is to be installed when using the grooved flange in conjunction with a rubber lined valve or serrated faced flange. It’s purpose is to separate two rubber surfaces from coming in contact with each other, which would lead to joint failure. It is important to note that there should never be a rubber to rubber (or similar material) joint, when installing any type of pipe system.

- Carbon steel conforming to ASTM A 1011
- Zinc electroplated standard carbon steel rings

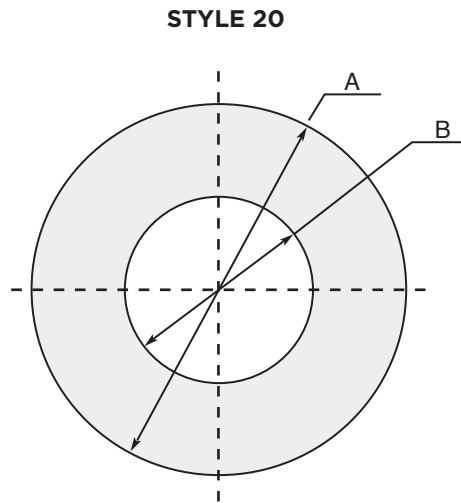

FLANGE ADAPTER INSERT - STYLE 20				
Size (NPS) (in.)	A (OD) (in.)	B (ID) (in.)	Thickness (in.)	Weight (lbs.)
2	4	2.25	.12	.30
2-1/2	4.75	2.75	.12	.40
3	5.25	3.40	.12	.42
4	6.75	4.37	.12	.69
5	7.64	5.43	.12	.75
6	8.63	6.50	.12	.84
8	10.87	8.50	.12	1.20
10	13.27	10.63	.12	1.65
12	16.0	12.65	.12	2.51

MECHANICAL TEE - GROOVED STYLE 15



- **Housing:** Ductile Iron conforming to ASTM A536, Grade 65-45-12
- **Bolts/Nuts:** Zinc electroplated carbon steel oval neck track head bolts conforming to ASTM A183 Grade 2 and SAE J429 Grade 5 with a minimum tensile strength of 110,000 psi. Zinc electroplated carbon steel heavy hex nut conforming to ASTM A536, Grade A.
- **Coatings:** Rust inhibiting orange paint (Standard) or Hot Dipped Galvanized (Optional) conforming to ASTM A153
- **Gasket Material:** Pre-Lubricated Grade “E” EPDM, Approved and Listed for use in Wet or Dry Systems
- **Gasket Temperature Range:** -40°F to 230°F (Service temperature range)
- **Lubrication:** Supplemental lubricant is recommended for services below 0°F and for all dry pipe systems or systems to be subjected to air tests prior to being filled with water.
- **Sizes:** 2” to 8”
- **Maximum Working Pressure:** 300 psi

Style 15 Mechanical Tee’s are bolted saddle type fittings designed for fast installation of bolted branch outlets as an alternative to welding connections.

Before installing, please read the Installation Instructions on page 40.

Obsolete-Style 15 is being replaced by Style 35

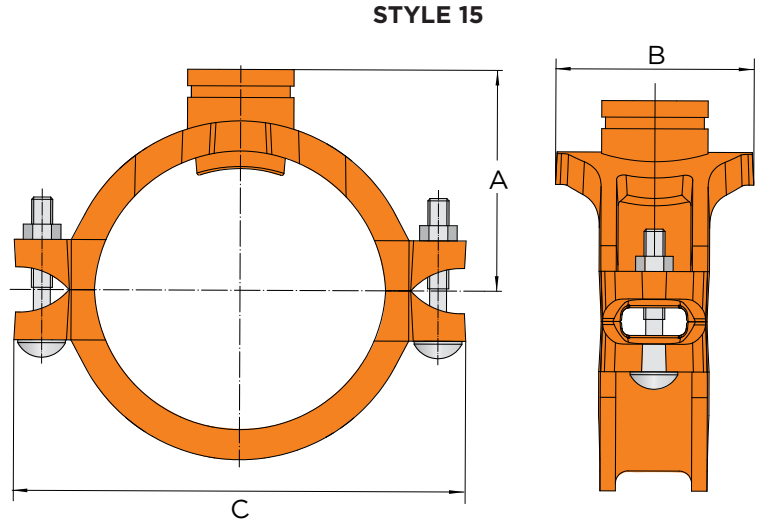

MECHANICAL TEE - GROOVED STYLE 15								
Run Size (in.)	Outlet Size (in.)	Max. Working Pressure (psi)*	Hole Diameter (in.)		Grooved Dimensions (in.)			Approx. Weight Each (lb.)
			Hole Saw	Max. Perm.	A	B	C	
2	1-1/4	300	1.75	1.91	2.32	2.71	4.57	1.77
	1-1/2	300	1.75	1.81	2.32	2.71	4.57	1.70
2-1/2	1-1/4	300	2	2.06	2.76	3.307	5.67	2.27
	1-1/2	300	2	2.06	2.76	3.267	5.67	2.47
3	1-1/4	300	2	2.06	2.76	3.23	5.98	2.50
	1-1/2	300	2	2.06	2.76	3.58	5.98	2.89
	2	300	2.5	2.55	3.23	2.4	5.98	3.23
4	1-1/4	300	2	2.06	3.66	3.27	7.32	3.40
	1-1/2	300	2	2.06	3.66	3.62	7.32	3.16
	2	300	2.5	2.55	3.66	3.82	7.4	3.30
	2-1/2	300	3	3.10	3.82	4.84	7.4	4.55
5	3	300	3.5	3.60	3.82	4.92	7.4	4.56
	1-1/2	300	2	2.06	4.21	3.62	8.56	4.27
	2	300	2.5	2.55	4.21	3.82	8.66	4.47
	2-1/2	300	2.75	2.81	4.21	4.84	8.66	5.27
6	3	300	3.5	3.60	4.21	5.35	8.66	6.03
	1-1/4	300	2	2.06	5.04	3.23	9.72	5.50
	1-1/2	300	2	2.06	5.04	3.62	9.72	5.55
	2	300	2.5	2.55	5.04	3.86	9.72	6.18
	2-1/2	300	3.25	3.35	5.04	4.84	9.72	5.32
	3	300	3.5	3.60	5.04	5.35	9.72	7.32
8	4	300	4.5	4.63	5.04	6.18	9.72	7.60
	2	300	2.5	2.55	5.98	5.11	12.2	7.50
	2-1/2	300	2.75	2.81	5.98	5.11	12.2	7.71
	3	300	3.5	3.60	5.98	5.39	12.2	8.3
	4	300	4.5	4.63	5.98	6.38	12.2	9.09

MECHANICAL TEE - GROOVED STYLE 35



- **Housing:** Ductile Iron conforming to ASTM A536, Grade 65-45-12
- **Bolts/Nuts:** Zinc electroplated carbon steel oval neck track head bolts conforming to ASTM A183 Grade 2 and SAE J429 Grade 5 with a minimum tensile strength of 110,000 psi. Zinc electroplated carbon steel heavy hex nut conforming to ASTM A536, Grade A.
- **Coatings:** Rust inhibiting orange paint (Standard) or Hot Dipped Galvanized (Optional) conforming to ASTM A153
- **Gasket Material:** Grade “E” EPDM, Approved and Listed for use in Wet or Dry Systems
- **Gasket Temperature Range:** -40°F to 230°F (Service temperature range)
- **Lubrication:** Supplemental lubricant is recommended for services below 0°F and for all dry pipe systems or systems to be subjected to air tests prior to being filled with water.
- **Sizes:** 2” to 8”
- **Maximum Working Pressure:** 300 psi

Style 35 Mechanical Tee’s are bolted saddle type fittings designed for fast installation of bolted branch outlets as an alternative to welding connections.

Before installing, please read the Installation Instructions on page 40.

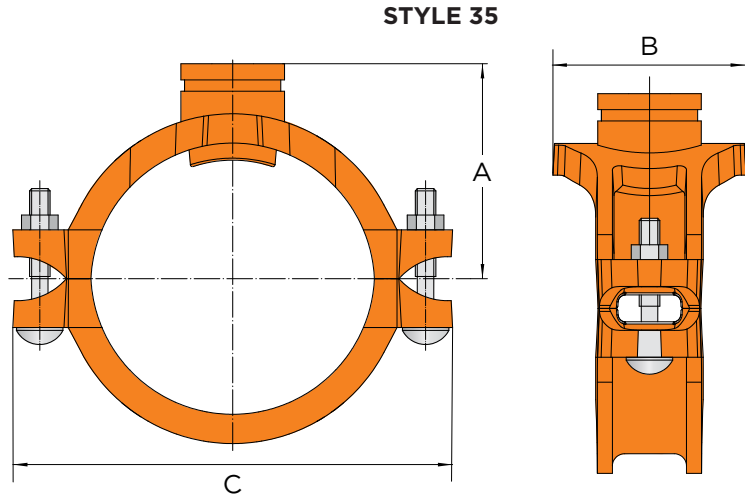

MECHANICAL TEE - GROOVED STYLE 35								
Run Size (in.)	Outlet Size (in.)	Max. Working Pressure (psi)*	Hole Diameter (in.)		Grooved Dimensions (in.)			Approx. Weight Each (lb.)
			Hole Saw	Max. Perm.	A	B	C	
2	1-1/4	300	1.75	1.85	2.32	2.72	4.57	1.76
	1-1/2	300	1.75	1.85	2.32	2.72	4.57	1.69
2-1/2	1-1/4	300	2.0	2.06	2.76	3.31	5.67	2.46
	1-1/2	300	2.0	2.13	2.95	3.31	5.67	2.33
	2*	300	2.5	2.63	3.07	3.35	5.35	2.63
3	1-1/4	300	2.0	2.06	2.76	3.23	5.98	2.50
	1-1/2	300	2.0	2.13	2.76	3.58	5.98	2.89
	2	300	2.5	2.63	3.23	3.85	5.98	3.23
4	1-1/4	300	2.0	2.06	3.66	3.27	7.32	3.40
	1-1/2	300	2.0	2.13	3.66	3.27	7.32	3.16
	2	300	2.5	2.63	3.66	3.82	7.40	3.30
	2-1/2	300	2.75	2.88	3.82	4.84	7.40	4.55
	3	300	3.5	3.55	3.82	4.92	7.40	4.56
5	2	300	2.5	2.63	4.21	3.82	8.66	4.47
	3	300	3.5	3.55	4.21	5.35	8.66	6.03
6	1-1/4	300	2.0	2.06	5.04	3.23	9.72	5.50
	1-1/2	300	2.0	2.13	5.04	3.62	9.72	5.55
	2	300	2.5	2.63	5.04	3.86	9.72	6.18
	2-1/2	300	2.75	2.87	5.04	4.84	9.72	5.32
	3	300	3.5	3.55	5.04	5.35	9.72	7.32
	4	300	4.5	4.63	5.04	6.18	9.72	7.60
8	2	300	2.5	2.63	5.98	3.82	12.20	7.50
	2-1/2	300	2.75	2.87	5.98	5.12	12.20	7.92
	3	300	3.5	3.63	5.98	5.40	12.20	8.30
	4	300	4.5	4.63	5.98	6.38	12.20	9.09

*UL/FM Approvals Pending

MECHANICAL TEE - THREADED STYLE 16



UL Listed
Under File No. EX15592

- **Housing:** Ductile Iron conforming to ASTM A536, Grade 65-45-12
- **Bolts/Nuts:** Zinc electroplated carbon steel oval neck track head bolts conforming to ASTM A183 Grade 2 and SAE J429 Grade 5 with a minimum tensile strength of 110,000 psi. Zinc electroplated carbon steel heavy hex nut conforming to ASTM A536, Grade A.
- **Coatings:** Rust inhibiting orange paint (Standard) or Hot Dipped Galvanized (Optional) conforming to ASTM A153
- **Gasket Material:** Pre-Lubricated Grade “E” EPDM, Approved and Listed for use in Wet or Dry Systems
- **Gasket Temperature Range:** -40°F to 230°F (Service temperature range)
- **Lubrication:** Supplemental lubricant is recommended for services below 0°F and for all dry pipe systems or systems to be subjected to air tests prior to being filled with water.
- **Sizes:** 1-1/2” to 8”
- **Threads:** NPT per ANSI/ASME B1.20.1
- **Maximum Working Pressure:** 300 psi

Style 16 Mechanical Tee’s are bolted saddle type fittings designed for fast installation of bolted branch outlets as an alternative to welding connections.

Before installing, please read the Installation Instructions on page 40.

Obsolete- Style 16 is being replaced by Style 36

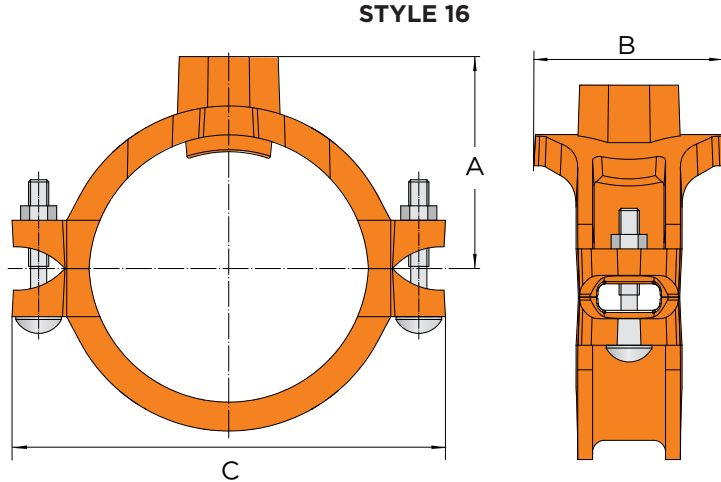

MECHANICAL TEE - THREADED STYLE 16								
Run Size (in.)	Outlet Size (in.)	Max. Working Pressure (psi)*	Hole Diameter (in.)		Threaded Dimensions (in.)			Approx. Weight Each (lb.)
			Hole Saw	Max. Perm.	A	B	C	
1-1/2	1	300	1.5	1.56	2.20	2.40	4.40	1.49
	2	300	1.5	1.56	2.36	2.71	4.567	1.53
2	1-1/4	300	2.0	2.06	2.36	2.71	4.567	1.66
	1-1/2	300	2.0	2.06	2.36	2.71	4.567	1.88
2-1/2	1	300	1.5	1.56	2.76	3.03	5.67	1.98
	1-1/4	300	2	2.06	2.76	3.27	5.67	2.36
3	1-1/2	300	2	2.06	2.76	3.27	5.67	2.33
	1	300	1.5	2.06	3.23	3.03	5.98	2.48
4	1-1/4	300	2	2.06	3.23	3.27	5.98	2.47
	1-1/2	300	2	2.06	3.23	3.62	5.98	2.60
5	2	300	2.5	2.55	3.23	3.89	5.98	2.96
	1	300	1.5	1.56	3.43	3.03	6.77	2.86
6	1-1/4	300	2	2.06	3.43	3.27	6.77	3.25
	1-1/2	300	2	2.06	3.43	3.62	6.77	3.25
7	2	300	2.5	2.55	3.43	3.82	6.77	3.55
	2-1/2	300	3.0	3.60	3.10	4.41	6.77	3.59
8	3	300	3.5	2.55	3.60	4.9	6.77	4.84
	1-1/2	300	2	2.06	3.94	3.62	8.27	3.65
9	2	300	2.5	2.55	3.94	3.82	8.27	3.89
	2-1/2	300	3.25	3.35	3.94	4.84	8.27	6.0
10	3	300	3.5	3.60	3.94	4.84	8.27	6.04
	1-1/4	300	2	2.06	4.61	3.27	9.53	5.32
11	1-1/2	300	2	2.06	4.61	3.62	9.53	5.80
	2	300	2.5	2.55	4.61	3.82	9.53	5.96
12	2-1/2	300	3.25	3.35	4.61	4.84	9.53	5.31
	3	300	3.5	3.60	4.61	5.35	9.53	7.32
13	2-1/2	300	3.25	3.35	5.75	5.11	12.2	7.48
	3	300	3.5	3.60	5.75	5.39	12.2	8.3
14	4	300	4.5	4.63	5.75	6.38	12.2	10.17

MECHANICAL TEE - THREADED

STYLE 36

- **Housing:** Ductile Iron conforming to ASTM A536, Grade 65-45-12
- **Bolts/Nuts:** Zinc electroplated carbon steel oval neck track head bolts conforming to ASTM A183 Grade 2 and SAE J429 Grade 5 with a minimum tensile strength of 110,000 psi. Zinc electroplated carbon steel heavy hex nut conforming to ASTM A536, Grade A.
- **Coatings:** Rust inhibiting orange paint (Standard) or Hot Dipped Galvanized (Optional) conforming to ASTM A153
- **Gasket Material:** Grade "E" EPDM, Approved and Listed for use in Wet or Dry Systems
- **Gasket Temperature Range:** -40°F to 230°F (Service temperature range)
- **Lubrication:** Supplemental lubricant is recommended for services below 0°F and for all dry pipe systems or systems to be subjected to air tests prior to being filled with water.
- **Sizes:** 2" to 8"
- **Threads:** NPT per ANSI/ASME B1.20.1
- **Maximum Working Pressure:** 300 psi

Style 36 Mechanical Tee's are bolted saddle type fittings designed for fast installation of bolted branch outlets as an alternative to welding connections.

Before installing, please read the Installation Instructions on page 40.

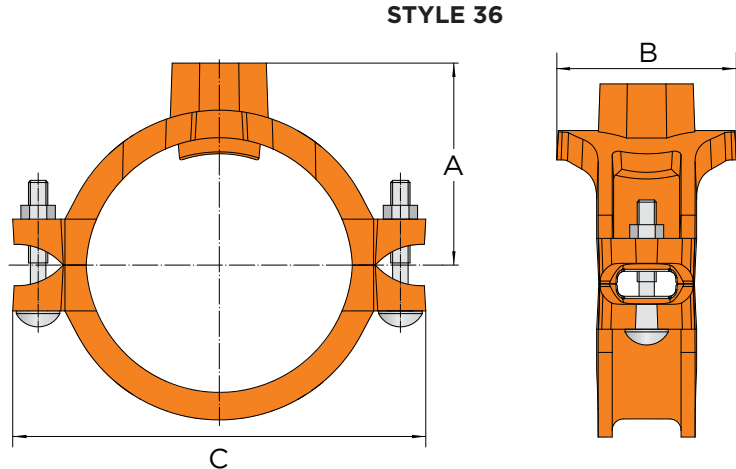

MECHANICAL TEE - THREADED STYLE 36								
Run Size (in.)	Outlet Size (in.)	Max Working Pressure (psi)*	Hole Diameter (in.)		Threaded Dimensions (in.)			Approx. Weight Each (lb.)
			Hole Saw	Max. Perm.	A	B	C	
2	1	300	1.5	1.63	2.36	2.72	4.57	1.45
	1-1/4	300	1.75	1.85	2.36	2.72	4.57	1.66
	1-1/2	300	1.75	1.85	2.36	2.72	4.57	1.88
2-1/2	1	300	1.5	1.63	2.60	3.07	5.70	1.98
	1-1/4	300	2.0	2.13	2.76	3.27	5.67	2.36
	1-1/2	300	2.0	2.13	2.36	3.27	5.67	2.33
	2*	300	2.5	2.63	3.07	3.35	5.35	2.88
3	1	300	1.5	1.63	3.23	3.03	5.98	2.48
	1-1/4	300	2.0	2.13	3.23	3.27	5.98	2.47
	1-1/2	300	2.0	2.13	3.23	3.62	5.98	2.60
	2	300	2.5	2.63	3.23	3.90	5.98	2.96
4	1	300	1.5	1.63	3.66	3.03	7.40	2.86
	1-1/4	300	2.0	2.13	3.66	3.27	7.40	3.25
	1-1/2	300	2.0	2.13	3.66	3.62	7.40	3.25
	2	300	2.5	2.63	3.66	3.82	7.40	3.55
	2-1/2	300	2.75	2.87	3.66	4.41	7.40	3.59
	3	300	3.5	3.63	3.66	4.92	7.40	4.84
5	1-1/2	300	2.0	2.13	3.94	3.62	8.66	3.65
	2	300	2.5	2.63	4.21	3.82	8.66	3.89
	3	300	3.5	3.63	4.21	5.35	8.66	6.04
6	1-1/4	300	2.0	2.13	4.72	3.23	9.72	5.32
	1-1/2	300	2.0	2.13	4.72	3.62	9.72	5.80
	2	300	2.5	2.63	4.72	3.86	9.72	5.96
	2-1/2	300	2.75	2.87	4.72	4.84	9.72	5.31
	3	300	3.5	3.55	4.72	5.35	9.72	7.32
	4	300	4.5	4.63	4.72	6.18	9.72	7.60

*UL/FM Approvals Pending

TEE LOCK STYLE 13*



UL Listed
Under File No. EX15592

- **Housing:** Ductile Iron conforming to ASTM A536, Grade 65-45-12
- **U-Bolts/Nuts:** Zinc electroplated carbon steel oval U-bolt conforming SAE J429 Grade 2. Zinc electroplated carbon steel hex flanged lock nuts conforming to ASTM A536, Grade A.
- **Coatings:** Uncoated bare ductile iron (Standard) or Hot Dipped Galvanized (Optional) conforming to ASTM A153
- **Gasket Material:** Grade “E” EPDM, Approved and Listed for use in Wet or Dry Systems
- **Gasket Temperature Range:** -40°F to 230°F (Service temperature range)
- **Sizes:** 1-1/4” to 2-1/2”
- **Threads:** NPT per ANSI/ASME B1.20.1
- **Maximum Working Pressure:** 300 psi

Style 13 Tee Locks are designed for fast installation of bolted branch outlets.

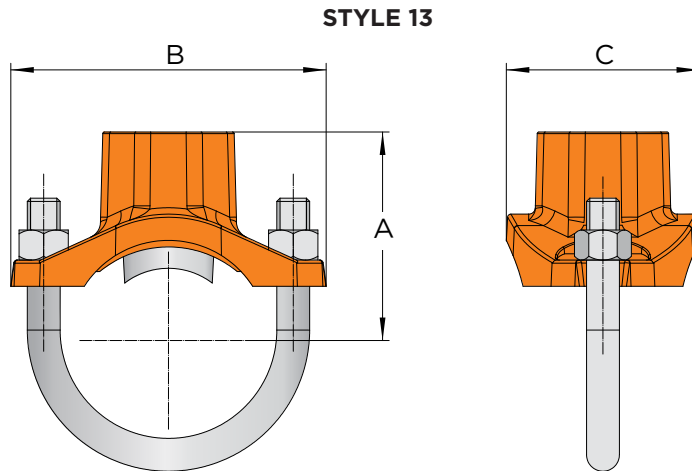

* Due to updated UL requirements the Style 13 is being replaced with the GemLock® Style 13A

TEE LOCK STYLE 13						
Nominal Size (in.)	Max. Working Pressure (psi)	Hole Saw (in.)	Dimensions (in.)			Weight (lbs.)
			A	B	C	
1-1/4 x 1/2	300	1-3/16	1.693	3.543	2.205	0.78
1-1/4 x 3/4	300	1-3/16	1.772	3.543	2.205	0.85
1-1/4 x 1	300	1-3/16	1.969	3.543	2.20	0.95
1-1/2 x 1/2	300	1-3/16	1.693	3.661	2.323	0.78
1-1/2 x 3/4	300	1-3/16	2.126	3.661	2.323	0.89
1-1/2 x 1	300	1-3/16	2.283	3.661	2.323	0.98
2 x 1/2	300	1-3/16	2.126	3.780	2.323	0.82
2 x 3/4	300	1-3/16	2.205	3.780	2.323	0.90
2 x 1	300	1-3/16	2.598	3.780	2.323	1.02
2-1/2 x -1/2	300	1-3/16	2.362	4.331	2.323	0.90
2-1/2 x 3/4	300	1-3/16	2.480	4.331	2.323	0.93
2-1/2 x 1	300	1-3/16	2.756	4.331	2.323	0.95

TEE LOCK STYLE 13A*



- **Housing:** Ductile Iron conforming to ASTM A536, Grade 65-45-12
- **U-Bolts/Nuts:** Zinc electroplated carbon steel oval U-bolt conforming to SAE J429 Grade 2. Zinc electroplated carbon steel hex flanged lock nuts conforming to ASTM A536, Grade A.
- **Coatings:** Uncoated bare ductile iron (Standard) or Hot Dipped Galvanized (Optional) conforming to ASTM A153
- **Gasket Material:** Grade “E” EPDM, Approved and Listed for use in Wet or Dry Systems
- **Gasket Temperature Range:** -40°F to 230°F (Service temperature range)
- **Sizes:** 1-1/4” to 2-1/2”
- **Threads:** NPT per ANSI/ASME B1.20.1
- **Maximum Working Pressure:** 300 psi

Style 13A Tee Locks are designed for fast installation of bolted branch outlets.

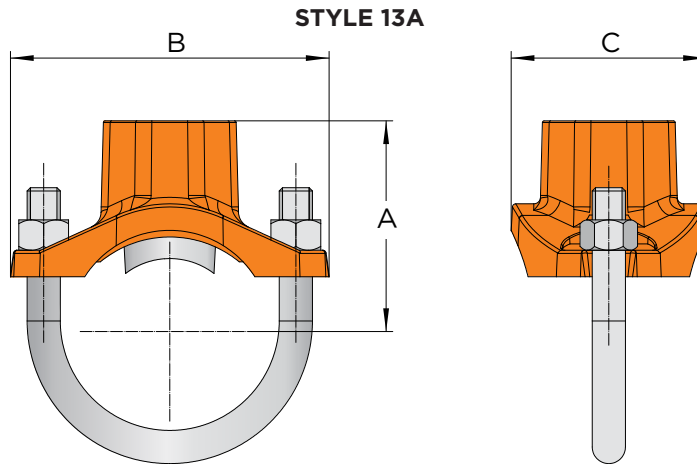

* Designed to meet UL’s most recent flow requirements

TEE LOCK STYLE 13A							
Nominal Size (in.)	Max. Working Pressure (psi)	Hole Saw (in.)		Dimensions (in.)			Weight (lbs.)
		Min.	Max.	A	B	C	
1-1/4 x 1/2	300	1-5/16	1-3/8	1.693	3.543	2.205	0.78
1-1/4 x 3/4	300	1-5/16	1-3/8	1.772	3.543	2.205	0.85
1-1/4 x 1	300	1-5/16	1-3/8	1.969	3.543	2.20	0.95
1-1/2 x 1/2	300	1-5/16	1-3/8	1.693	3.661	2.323	0.78
1-1/2 x 3/4	300	1-5/16	1-3/8	2.126	3.661	2.323	0.89
1-1/2 x 1	300	1-5/16	1-3/8	2.283	3.661	2.323	0.98
2 x 1/2	300	1-5/16	1-3/8	2.126	3.780	2.323	0.82
2 x 3/4	300	1-5/16	1-3/8	2.205	3.780	2.323	0.90
2 x 1	300	1-5/16	1-3/8	2.598	3.780	2.323	1.02
2-1/2 x -1/2	300	1-5/16	1-3/8	2.362	4.331	2.323	0.90
2-1/2 x 3/4	300	1-5/16	1-3/8	2.480	4.331	2.323	0.93
2-1/2 x 1	300	1-5/16	1-3/8	2.756	4.331	2.323	0.95

GROOVED FITTINGS SHORT PATTERN

STYLES F105, F106, F107, F135



- **Fittings:** Ductile Iron conforming to ASTM A536, Grade 65-45-12
- **Coatings:** Rust inhibiting orange paint (Standard) or Hot Dipped Galvanized (Optional) conforming to ASTM A153
- **Sizes:** 1-1/2" to 8"
- **Maximum Working Pressure:** 300 psi

Short pattern products are all full flow design, specifically for use in Fire Protection applications.

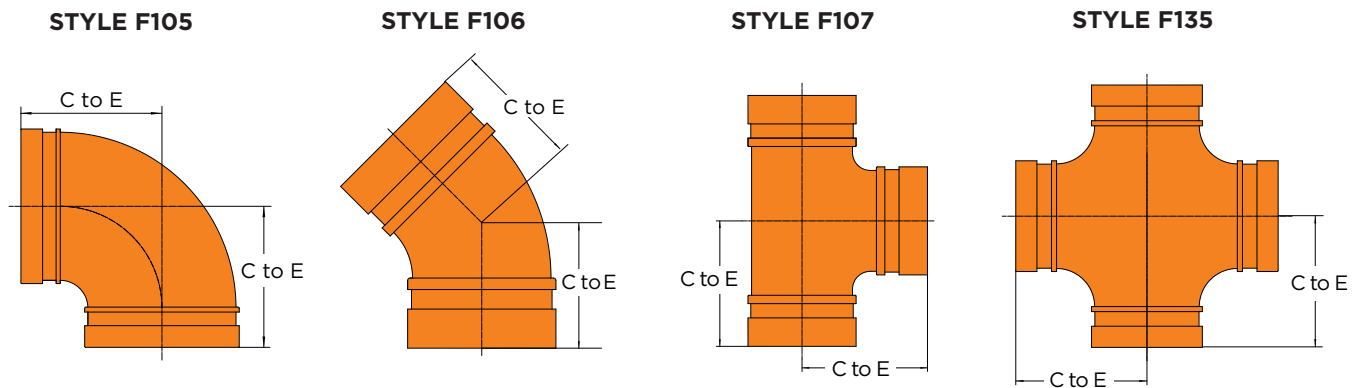

GROOVED FITTINGS - SHORT PATTERN									
Pipe		90° Elbow No. F105		45° Elbow No. F106		Equal Tee No. F107		Cross No. F135	
Nominal Size (in.)	Actual Size (in.)	C to E (in.)	Approx. Wgt. Ea. (lb.)	C to E (in.)	Approx. Wgt. Ea. (lb.)	C to E (in.)	Approx. Wgt. Ea. (lb.)	C to E (in.)	Approx. Wgt. Ea. (lb.)
1-1/2	1.9	2.362	1.01	1.73	.78	2.362	1.34	2.75	2.5
2	2.375	2.755	1.24	2.00	1.20	2.755	1.98	2.75	2.49
2-1/2	2.875	2.992	2.03	2.24	1.63	2.992	2.82	2.99	3.19
3	3.5	3.368	2.53	2.52	2.38	3.386	3.90	3.38	5.09
4	4.5	3.996	3.74	3.00	3.84	3.996	5.72	3.99	7.22
5	5.563	4.803	7.20	3.28	5.74	4.803	9.52	4.80	7.23
6	6.625	5.61	9.06	3.51	8.11	5.5	14.13	5.5	15.97
8	8.625	6.889	20.52	4.25	14.27	6.889	27.07	6.88	28.66

STANDARD GROOVED FITTINGS STYLES 100, 101, 102, 103, 110 & 150



- **Fittings:** Ductile Iron conforming to ASTM A536, Grade 65-45-12
- **Coatings:** Rust inhibiting orange paint (Standard) or Hot Dipped Galvanized (Optional) conforming to ASTM A153
- **Sizes:** 1" to 12"
- **Maximum Working Pressure:** 300 psi

STYLE 100

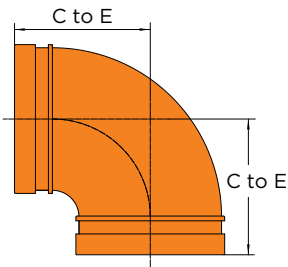

STYLE 102

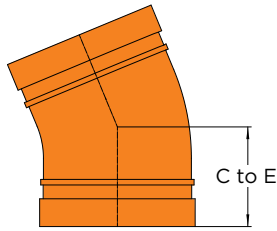

STYLE 103

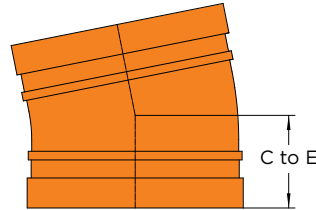

STYLE 110

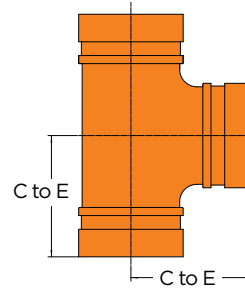

STYLE 150

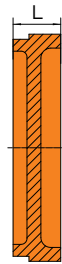

STANDARD GROOVED FITTINGS

Pipe		90° Elbow No. 100		22-1/2° Elbow No. 102		11-1/4° Elbow No.103		Equal Tee No.110		End Cap No.150	
Nominal Size (in.)	Actual Size (in.)	C to E (in.)	Approx. Wgt. Ea. (lb.)	C to E (in.)	Approx. Wgt. Ea. (lb.)	C to E (in.)	Approx. Wgt. Ea. (lb.)	C to E (in.)	Approx. Wgt. Ea. (lb.)	L (in.)	Approx. Wgt. Ea. (lb.)
1	1.315	2.24	.85	1.61	.45	1.38	.42	2.24	1.45	0.96	.25
1-1/4	1.66	2.755	1.17	1.732	.80	1.38	0.55	2.755	1.52	0.96	.33
1-1/2	1.9	2.755	1.17	1.732	.84	1.38	0.63	2.755	1.74	0.96	0.44
2	2.375	3.257	2.25	2.0	1.14	1.38	0.82	3.267	2.5	0.96	0.61
2-1/2	2.875	3.74	2.76	2.0	1.50	1.5	1.22	3.74	3.73	0.96	0.85
3	3.5	4.251	3.44	2.24	2.53	1.5	1.62	4.251	6.24	0.96	1.01
4	4.5	5.0	5.32	2.87	3.91	1.89	2.63	5.0	8.70	0.99	1.42
5	5.563	5.51	8.0	2.87	5.10	2.0	3.90	5.51	12.44	0.99	2.80
6	6.625	6.496	14.31	3.11	7.16	2.0	4.78	6.496	18.21	0.99	4.40
8	8.625	7.755	21.63	3.86	11.88	2.0	7.10	7.755	33.25	1.181	9.30
10	10.75	8.464	37.04	4.37	14.0	2.13	14.5	8.464	46.35	1.26	9.33
12	12.75	9.645	57.25	4.88	22.0	2.25	25.5	9.645	59.50	1.26	13.25

REDUCING TEE - SHORT PATTERN STYLE 115



- **Fittings:** Ductile Iron conforming to ASTM A536, Grade 65-45-12
- **Coatings:** Rust inhibiting orange paint (Standard) or Hot Dipped Galvanized (Optional) conforming to ASTM A153
- **Sizes:** 2" to 10"
- **Maximum Working Pressure:** 300 psi

STYLE 115

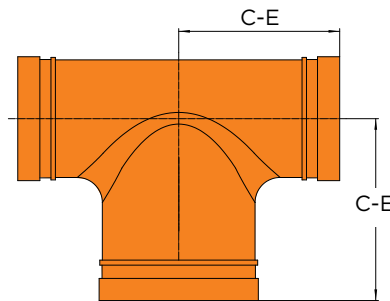

REDUCER TEE - NO. 115 (Add after part number the letters TF for internal or TM for external threaded outlet)		
Nominal Size (in.)	C to E (in.)	Approx. Wgt. Ea. (lb.)
2-1/2 x 2-1/2 x 2	3.00	5.1
3 x 3 x 2	3.39	8.4
3 x 3 x 2-1/2	3.39	8.6
4 x 4 x 2	4.00	10.4
4 x 4 x 2-1/2	4.00	11.4
4 x 4 x 3	4.00	11.6
5 x 5 x 2	4.80	14.5
5 x 5 x 3	4.80	15.4
5 x 5 x 4	4.80	16.1
6 x 6 x 2	5.51	26.4
6 x 6 x 2-1/2	5.51	26.5
6 x 6 x 3	5.51	26.5
6 x 6 x 4	5.51	29.3
6 x 6 x 5	5.51	30.9
8 x 8 x 2	6.90	33.5
8 x 8 x 2-1/2	6.90	39.0
8 x 8 x 3	6.90	33.6
8 x 8 x 4	6.90	47.4
8 x 8 x 5	6.90	48.3
10 x 10 x 4	9.0	79.4
10 x 10 x 5	9.0	78.9
10 x 10 x 6	9.0	78.3
10 x 10 x 8	9.0	77.2

STANDARD REDUCERS CONCENTRIC - STYLE 140 ECCENTRIC - STYLE 145



- **Fittings:** Ductile Iron conforming to ASTM A536, Grade 65-45-12
- **Coatings:** Rust inhibiting orange paint (Standard) or Hot Dipped Galvanized (Optional) conforming to ASTM A153
- **Sizes Standard Concentric Reducer:** 1-1/2" to 10"
Sizes Eccentric Reducer: 3" to 10"
- **Maximum Working Pressure:** 300 psi

STYLE 140

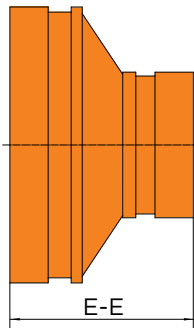

STYLE 145

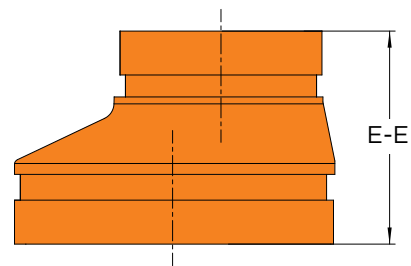

CONCENTRIC REDUCER - NO. 140			CONCENTRIC REDUCER - NO. 140		
Nominal Size (in.)	E to E (in.)	Approx. Wgt. Ea. (lb.)	Nominal Size (in.)	E to E (in.)	Approx. Wgt. Ea. (lb.)
1-1/2 x 1-1/4	2.52	.60	6 x 2-1/2	4.02	4.10
2 x 1	2.52	.72	6 x 3	4.02	4.12
2 x 1-1/4	2.52	.69	6 x 4	4.02	4.63
2 x 1-1/2	2.52	.72	6 x 5	4.02	4.35
2-1/2 x 1-1/4	2.52	.91	8 x 3	5	7.71
2-1/2 x 1-1/2	2.52	.92	8 x 4	5	6.76
2-1/2 x 2	2.52	1.02	8 x 5	5	7.71
3 x 1	2.52	1.10	8 x 6	5	8.15
3 x 1-1/4	2.52	1.15	10 x 4	5.98	20.0
3 x 1-1/2	2.52	1.16	10 x 6	5.98	14.48
3 x 2	2.52	1.21	10 x 8	5.98	14.16
3 x 2-1/2	2.52	1.25			
4 x 1	3.00	2.2			
4 x 2	3.00	2.4			
4 x 2-1/2	3.00	2.7			
4 x 3	3.00	2.8			
5 x 2	3.5	3.8			
5 x 4	3.5	2.95			
6 x 2	4.02	4.36			

ECCENTRIC REDUCER - NO. 145		
Nominal Size (in.)	E to E (in.)	Approx. Wgt. Ea. (lb.)
3 x 2	2.52	1.8
3 x 2-1/2	2.52	1.6
4 x 2	3.00	2.6
4 x 2-1/2	3.00	2.8
4 x 3	3.00	3.3
5 x 2-1/2	3.50	10.8
5 x 3	3.50	11
5 x 4	3.50	5.1
6 x 2-1/2	4.02	14.1
6 x 3	4.02	14.9
6 x 4	4.02	6.6
6 x 5	4.02	9.4
8 x 3	5.00	22.0
8 x 4	5.00	22.9
8 x 5	5.00	26.5
8 x 6	5.00	30.8
10 x 6	5.98	36.5
10 x 8	5.98	38

STANDARD DRAIN ELBOW



STYLE F100D

Cast Fittings: Ductile Iron conforming to ASTM A536, Grade 65-45-12

- **Fabricated Fittings:** Carbon Steel Schedule 10
- **Coatings:** Rust inhibiting orange paint (Standard) or Hot Dipped Galvanized (Optional) conforming to ASTM A153
- **Cast Fitting Sizes:** 2" to 8"
- **Threads:** NPT per ANSI/ASME B1.20.1
- **Maximum Working Pressure:** 300 psi

Drain Elbow comes standard with 1" female NPT outlet per ASME B1.20.1

DRAIN ELBOW - STANDARD STYLE F100D

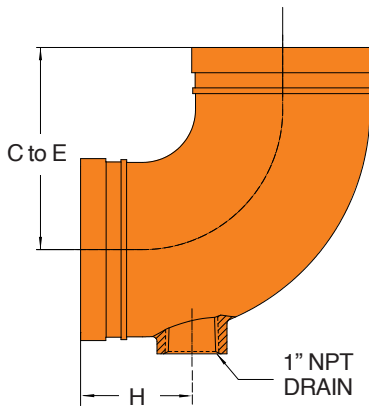

DRAIN ELBOW - STANDARD STYLE F100D				
Pipe		Dimensions (in.)		Approx. wgt. Ea. (lb.)
Nominal Size (in.)	Actual Size (in.)	C to E	H	
2	2.375	3.27	2.75	3.8
2-1/2	2.875	3.75	2.75	5.2
3	3.500	4.25	2.75	5.3
4	4.500	5.00	2.75	8.8
6	6.625	6.50	2.75	18.7
8	8.625	7.8	2.75	31.0

DRAIN TEE STYLE 115D

- Fabricated from ASTM A53 SCH 40 pipe
- Standard grooves to AWWA C606
- Threads are MNPT
- Available with Hot Dipped galvanized coating for corrosive environments
- Rated for 300 psi

STYLE 115D

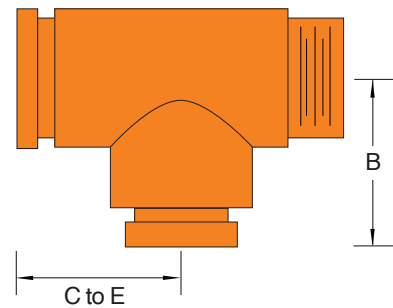

DRAIN TEE - STYLE 115D			
Nominal Size (in.)	Dimensions		Weight (lbs.)
	C-E	B	
1-1/4	2-3/4	2-3/4	1.4
1-1/2	2-3/4	2-3/4	1.6

STANDARD DRAIN CAP STYLE F155D



- **Cast Fittings:** Ductile Iron conforming to ASTM A536, Grade 65-45-12
- **Fabricated Fittings:** Carbon Steel Schedule 10
- **Coatings:** Rust inhibiting orange paint (Standard) or Hot Dipped Galvanized (Optional) conforming to ASTM A153
- **Cast Fitting Sizes:** 2" to 8"
- **Fabricated Fitting Sizes:** 1-1/4" to 1-1/2"
- **Threads:** NPT per ANSI/ASME B1.20.1
- **Maximum Working Pressure:** 300 psi

Drain Cap comes standard with 1" female NPT outlet per ASME B1.20.1 sizes 1-1/4" to 6" and 2" Female NPT outlet per ASME B1.20.1 on 8.

STYLE F155D

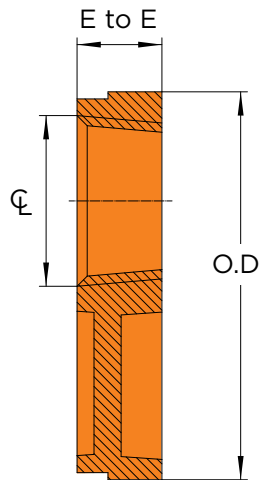

FIGURE F155D CAP

Nominal Size	O.D.	End to End	Outlet Size	Approx. wgt. Ea.
in./DN	in.	in.	in.	lbs.
1-1/4	1.660	1-1/4	1	0.4
1-1/2	1.900	1-1/4	1	0.5
2	2.375	1	1	0.5
2-1/2	2.875	1	1	0.7
3	3.500	1	1	1.1
4	4.500	1-1/8	1	2.8
5	5.563	1-1/8	1	4.0
6	6.625	1-5/16	1	6.0
8	8.625	1-1/2	2	12.5

90° ADAPTER ELL STYLE 105TL



- Transitions from grooved to threaded connection
- Direct connection to sprinkler heads
- Available in rust inhibitive black paint & galvanized finish
- Made of durable, high-strength ductile iron conforming to ASTM A536, Gr 65-45-12; every lot is metallurgically tested for compliance
- Rated for 500 psi

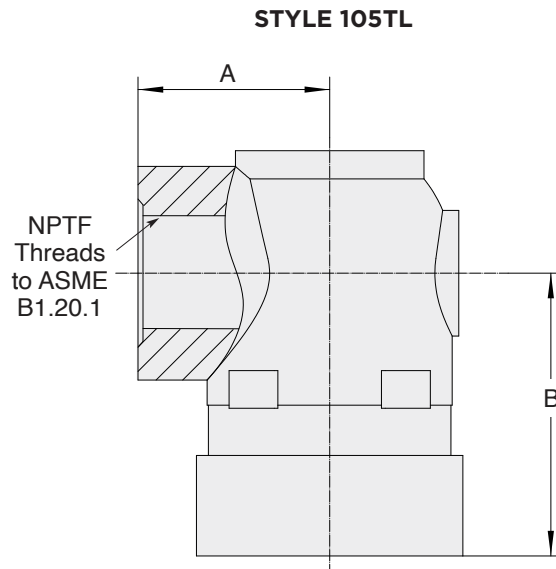

90° ADAPTER ELL			
Nominal Size (in.)	Max. Work Pressure (psi)	Dimensions (in.)	
		A	B
1-1/4 x 1/2	500	1.77	1.20
1-1/4 x 3/4	500	1.77	1.20
1-1/4 x 1	500	1.91	1.24
1-1/2 x 1/2	500	1.77	1.32
1-1/2 x 3/4	500	1.77	1.32
1-1/2 x 1	500	1.91	1.32
2 x 1/2	500	1.75	1.57
2 x 3/4	500	1.77	1.57
2 x 1	500	1.91	1.63
2-1/2 x 1/2	500	1.75	1.75
2-1/2 x 3/4	500	1.75	1.75
2-1/2 x 1	500	1.91	1.81

MODEL LVCVGG-400

- **Leak-Tight Sealing:** Equipped with an EPDM non-stick rubber ring for reliable, leak-tight sealing corrosion resistance: All wetted parts are made from stainless steel, providing superior corrosion resistance.
- **Durable Coating:** Both the interior and exterior surfaces are coated with a fusion-bonded coating that meets or exceeds the AWWA C550 Standard
- **Pressure Rating:** Rated for 400 psi across all sizes
- **Certification:** UL Listed and FM Approved for safety and reliability in fire protection applications
- **Body:** Ductile Iron (ASTM A536)
- **Seat Ring:** Brass (ASTM C37700)
- **Clapper:** Stainless Steel (ASTM A240)
- **Rubber Ring:** EPDM
- **Spring:** Stainless Steel (ASTM A240)
- **Hinge Pin:** Stainless Steel (ASTM A240)

The LVCVGG-400 Grooved End Swing Check Valve is engineered for reliability and efficiency in fire protection systems. It is designed to be installed in either horizontal or vertical lines with upward flow, offering versatility in various installation scenarios. The valve features a low pressure drop and is easier and faster to maintain and install compared to traditional valves.

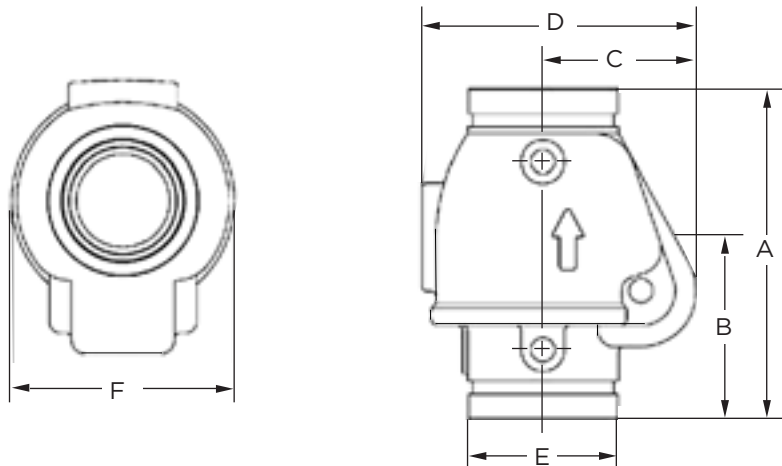

DIMENSIONS								
Nominal Valve Size (In.) (DN)	Pipe OD (In.)	Nominal Dimensions (In.)						Weight (Lbs.)
		A	B	C	D	E	F	
2	2.37	6.34	3.54	2.80	5.02	2.37	4.21	6.24
2-1/2	2.88	7.06	3.91	3.19	5.71	2.87	4.74	8.80
3	3.5	7.80	4.29	3.61	6.44	3.5	5.24	13.23
4	4.5	8.62	4.06	4.25	7.71	4.50	6.49	19.84
6	6.63	10.38	5.12	5.43	9.56	6.63	8.00	37.48

MODEL LVCVGG-RF

- Grooved connections are cut in accordance with AWWA C606
- Maximum Working Pressure: 300 psi
- Removable inspection cover
- Spring assisted clapper

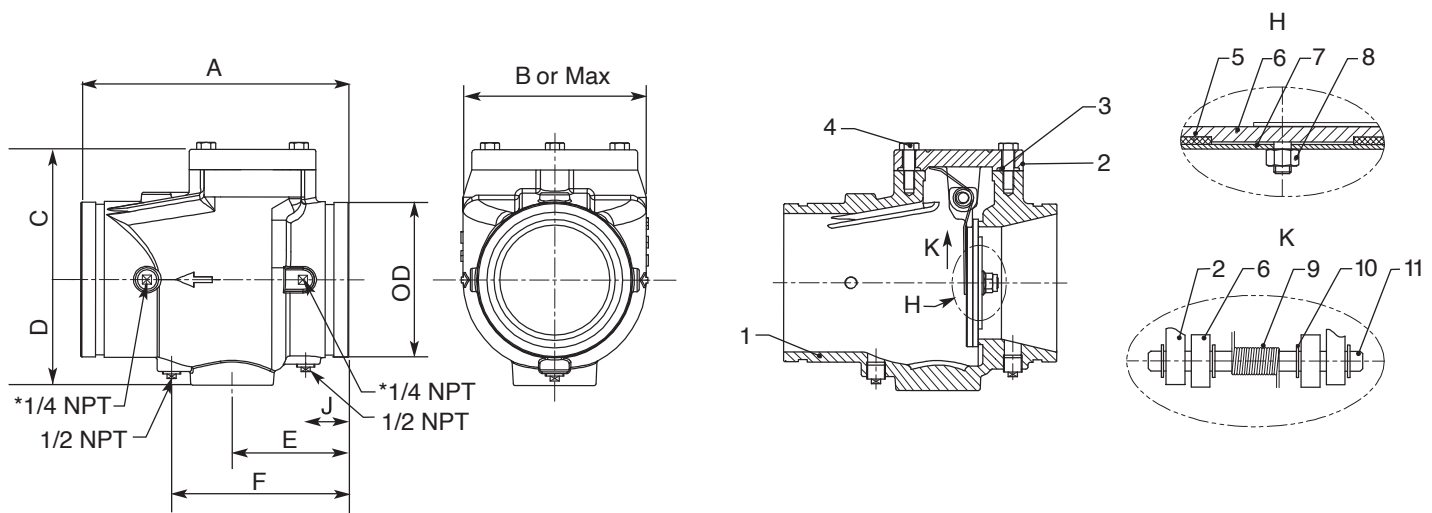

MATERIAL SPECIFICATION			
Part NO.	Part	Material	ASTM Specification
1	Body	Ductile Iron	ASTM A536 Gr. 65-45-12
2	Cover	Ductile Iron	ASTM A536 Gr. 65-45-12
3	Cover Gasket	Rubber	D2000 EPDM
4	Bolts & Washers	Carbon Steel	ASTM A307 Gr. B
5	Clapper Facing	Rubber	D2000 EPDM
6	Clapper 2"- 8"	Stainless Steel	ASTM A276 Gr. 304
	Clapper 10"- 12"	Ductile Iron	ASTM A536 Gr. 65-45-12
7	Retaining Disc	Stainless Steel	ASTM A276 Gr. 304
8	Locknut	Stainless Steel	ASTM A276 Gr. 304
9	Spring	Stainless Steel	ASTM A276 Gr. 304
10	Retaining Ring	Stainless Steel	ASTM A276 Gr. 304
11	Hinge Shaft	Stainless Steel	ASTM A276 Gr. 304

NOMINAL PIPE SIZE		NOMINAL DIMENSIONS						
Valve Size (in.)	PIPE O.D./ (in.)	A	B	C	D	E	F	J
2	2.38	6.75	4.10	2.48	2.17	3.27	4.76	1.63
2-1/2	2.88	8.00	4.57	2.76	2.76	3.86	5.87	1.65
3	3.50	8.37	5.35	3.11	3.15	3.86	5.87	1.65
4	4.50	9.63	6.30	3.98	3.62	4.53	7.13	1.81
5	5.56	10.50	7.40	4.46	4.13	4.90	7.50	1.75
6	6.63	11.50	7.87	5.59	4.53	5.00	7.60	1.85
8	8.63	14.00	9.92	6.85	5.51	5.43	8.46	2.13
10	10.75	18.00	12.38	8.62	6.41	7.50	10.50	3.00
12	12.75	21.00	14.28	9.93	7.27	7.62	10.62	2.75

RISER CHECK ASSEMBLY (SHOT GUN RISER)

MODEL LVRCGG

- Meet or exceeds the requirements of UL 312 and FM 1210 standard
- Spring loaded for fast closure
- Drain plug at the bottom under the inlet end for attaching a drain valve
- Excellent flow characteristics
- Superior design featuring exceptionally low pressure losses at high flow rates Rubber disc facing and bronze seat ring
- Grooved connections are cut in accordance with AWWA C606 standard grooved specifications for steel pipe
- UL 312/ULC listed and FM 1210 approved
- Fusion bonded coating interior and exterior meet or exceed all applicable of AWWA C550 standard
- 350 psi rated @ 0° C to 87° C

Lansdale's Riser Check Valve Assemblies are intended for use in wet pipe fire protection systems, as well as preaction systems where there is no need for a mechanical alarm. The use of a water flow switch can provide an electronic alarm. Grooved end connections provide fast and economical installation of a UL/FM Approved coupling, such as GemLock®. When installed vertically the direction of flow arrow should point upward. For horizontal installation, the hinge pin must be located at the top. If used in preaction system the valve must be installed vertically.

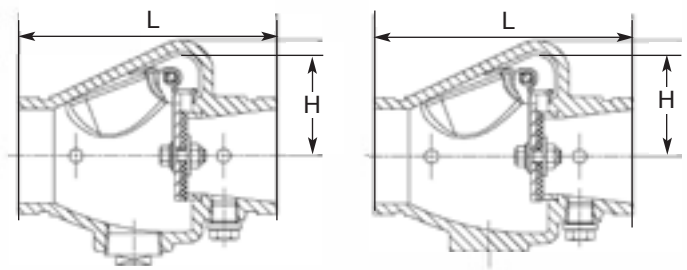
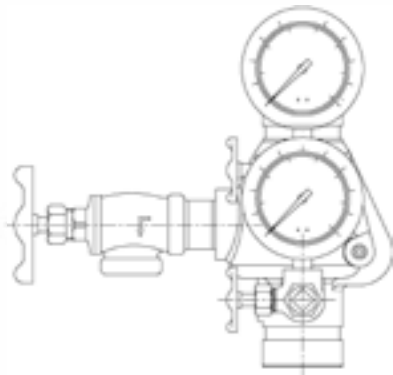

MAIN DIMENSIONS (in.)								
Size	1.25	1.5	2	2.5	3	4	6	8
L	6.3	6.3	6.7	7.2	7.8	8.6	10.62	12.8
H	2.5	2.5	3	3.13	3.5	4	5	6.3

MATERIAL SPECIFICATIONS		
Part NO.	Material	ASTM Specification
Body	Ductile Iron	A536 Grade 65-45-12
Body Seat Ring	Bronze	B62 C83600
Disc	Stainless Steel	A351 Grade CF8
Disc Facing	Rubber	D2000 EPDM
Spring	Stainless Steel	A276 Grade 302
Hinge Pin	Stainless Steel	A276 Grade 304
Disc Facing Bolt/Nut	Stainless Steel	A276 Grade 304
Angle Drain Valve	Bronze	B148 C95500
3-Way Valves	Bronze	B148 C95500
Nipples	Stainless Steel	A276 Grade 304
Air/Water Gauges	—	—

WAFER BUTTERFLY VALVE W/TAMPER

MODEL LVWBG

- Equipped with pre-wired tamper switches
- 2-1/2"- 8" 300 psi
- 10" & 12" 175 psi
- Rated for indoor & outdoor use
- Flag type position indicator
- Double tamper switch
- DI body encapsulated with a corrosion resistant durable polymer coating to ensure a long service life
- Disc is EPDM coated with SS stem for long service life
- Manufactured by Viatech exclusively for Lansdale Valve and Manufacturing

The Lansdale wafer butterfly valve is an NFPA compliant valve intended for use in the Fire Protection Industry. This valve is sandwiched between two CL 125/150 flanges and is usually used around the fire pump where there is flanged piping connections and space limitations.

Friction Loss Wafer Type Butterfly Valve

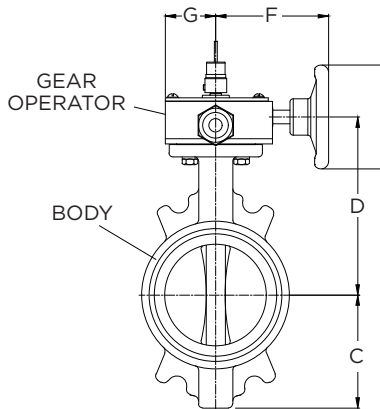
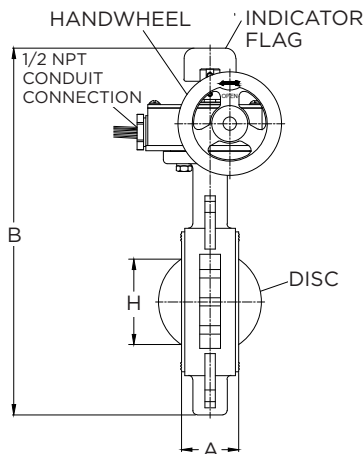
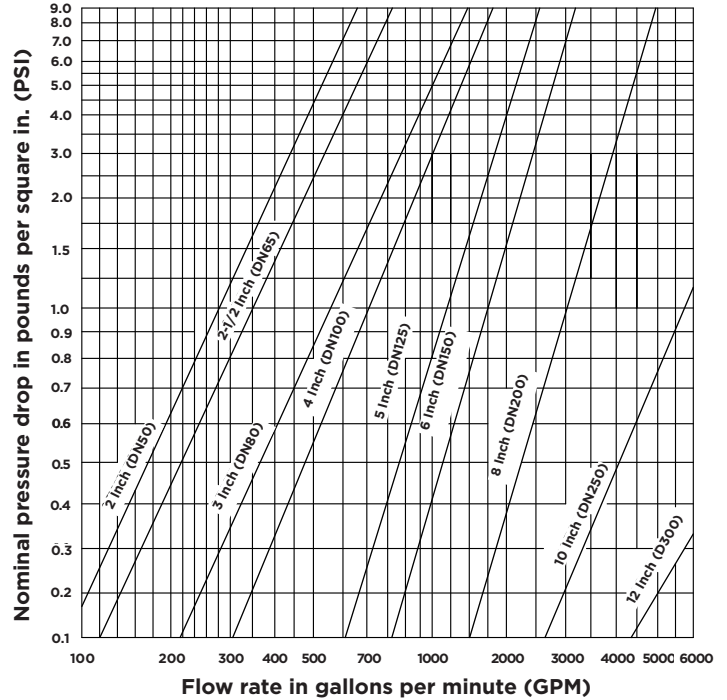

NOMINAL INSTALLATION DIMENSIONS (in.)									
Nominal Valve Size (in.) (DN)	A	B	C	D	E	F	G	H	Wgt. (lbs.)
2	1.50	10.63	2.85	4.90	4.92	4.28	1.99	1.40	11.46
2-1/2	1.81	11.67	3.35	5.45	4.92	4.28	1.99	1.65	13.4
3	1.81	12.27	3.58	5.81	4.92	4.28	1.99	2.34	14.77
4	2.16	13.92	4.29	6.75	4.92	4.28	1.99	3.25	15.65
5	2.4	16.0	5.16	7.93	5.91	5.79	2.23	4.0	26.68
6	2.4	17.07	5.71	8.44	5.91	5.79	2.32	5.22	25.35
8	2.48	19.63	6.69	9.29	8.86	8.19	2.76	7.3	44.75
10	3.03	23.01	8.27	11.1	11.14	8.19	2.91	9.05	64.6
12	3.15	25.16	9.5	12.2	11.14	8.19	2.91	11.53	86.42

MATERIAL LIST			
No.	Description	Material	Specification
1	Body	Iron	ASTM A536
2	Disc	Rubber	EPDM
3	Gear Operator	Iron	ASTM A536
4	Handwheel	Iron	ASTM A536
5	Indicator Flag	Nickel	ASTM A619

MODELS LPBT THREADED & LPBG GROOVED

Sprinkler Control Valve for indoor and outdoor use. Brass body, chrome plated brass disc, and 300 Psi. UL Listed/FM Approved. Available threaded in sizes 1" to 2-1/2" and grooved from 1-1/4" to 2-1/2". Complete with position indicator and integral tamper switch.

- Internal tamper switch for Indoor/Outdoor Use.
- Flag type indicator
- Prewired double tamper switch
- Elimination of water hammer
- Slow opening and closing

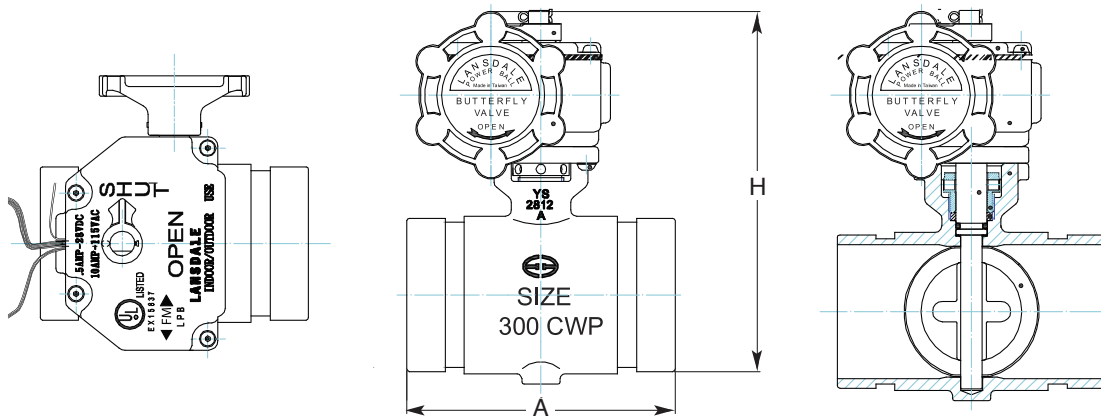

See Lansdale's Installation & Maintenance Manual for electrical schematics.

POWERBALL GROOVED	
Size (in.)	Weight
1-1/4	3.90
1-1/2	4.12
2	4.78
2-1/2	6.17

DIMENSIONS				
Size (in.)	1-1/4	1-1/2	2	2-1/2
A	3.86	4.02	4.09	4.49
H	5.20	5.47	6.07	6.58

POWERBALL THREADED	
Size (in.)	Weight
1	3.42
1-1/4	3.75
1-1/2	4.03
2	5.18
2-1/2	7.46

MATERIAL LIST		
No.	Name	Material List
1	Body	Bronze ASTM 584 C83600
2	Disc	SS304
3	Hand wheel	ASTM A216 WCB
4	Seat	ASTM D2000 VITON
5	Indicator	Powder Metal FD0205 95HT
6	Housing	Brass ASTM B16 C36000
7	Cover	Brass ASTM B16 C36000



LEVER HANDLE GROOVED BUTTERFLY VALVE

MODEL LV-GTV

- Rated for 300 psi
- Ductile iron - ASTM 536 body & disc
- Body - Epoxy coated
- Disc - EPDM, FKM, or NBR encapsulated

Lansdale's Lever Handle Grooved Butterfly Valve Model LV-GTV are indicating type valves designed for use in commercial plumbing and HVAC systems where a visual indication is required as to whether the valve is open or closed. These valves have a 10-position locking handle that can therefore be used as a flow control or isolation valve. They are used, for example, as system control valves and Isolation valves. They have grooved inlet and outlet connections that are suitable for use with grooved end pipe couplings that are approved for commercial plumbing and HVAC systems.

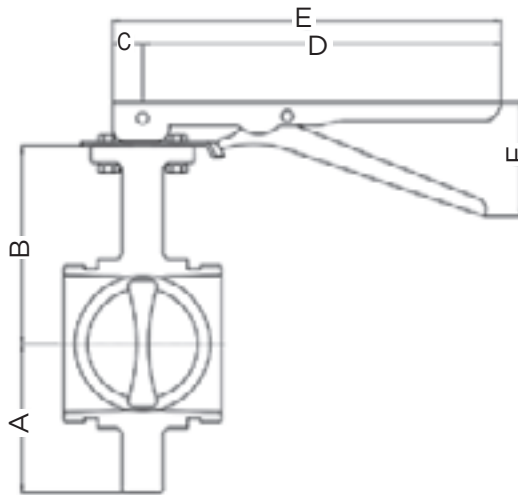

DIMENSIONAL DATA (in.)									
Nominal Valve Size (In.)	Pipe OD	B	C	D	E	F	G	G (End To End)	Wgt. (lbs.)
2	2.37	2.85	3.50	.87	10.35	11.25	2.56	3.19	4.0
2-1/2	2.88	3.35	4.45	.87	10.35	11.25	2.56	3.8	6.40
3	3.5	3.58	4.72	.87	10.35	11.25	2.56	3.8	7.50
4	4.5	4.29	5.71	.87	10.35	11.25	3.29	4.54	10.80
5	5.56	5.16	6.54	.87	10.35	11.25	3.29	5.21	16.76
6	6.63	5.71	7.05	.87	10.35	11.25	3.29	5.21	23.0
8	8.63	6.69	8.03	.87	10.35	11.25	3.29	5.8	32.40

MODELS LVBG1 (2" - 8") & LVBG3 (10" - 12")

- Model LVBG1 Rated 300 psi
- Model LVBG3 Rated 175 psi
- Indoor/Outdoor use
- Prewired double tamper switches/Normally Open
- Available Normally Closed
- Eliminates water hammer
- Slow open/slow close
- Flag type position indicator
- DI body encapsulated with a resistant durable polymer coating to ensure a long service life
- Disc is EPDM coated with SS stem

The Lansdale's grooved butterfly valve is an NFPA compliant valve designed and manufactured for the Fire Protection industry and used as a control or isolation valve within the fire protection system. See Lansdale's Installation & Maintenance Manual for electrical schematics.

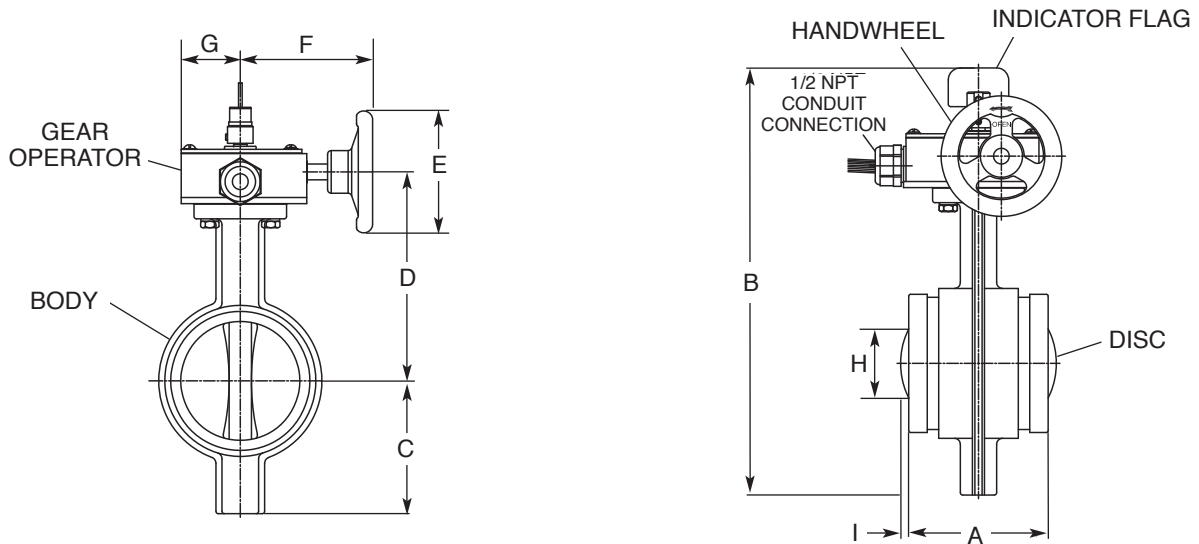

DIMENSIONAL DATA (in.)											
Nominal Valve Size (In.) (DN)	Pipe OD	A	B	C	D	E	F	G	H	I	Wgt. (lbs.)
2	2.37	3.8	10.63	2.85	4.90	4.92	4.28	1.99	0	0	9.6
2-1/2	2.88	3.8	11.72	3.35	5.5	4.92	4.28	1.99	0	0	11.24
3	3.5	3.8	12.22	3.58	5.76	4.92	4.28	1.99	0	0	12.57
4	4.5	4.54	13.92	4.29	6.75	4.92	4.28	1.99	0	0	15.65
5	5.56	5.21	16.0	5.16	7.93	5.91	5.79	2.44	0	0	25.8
6	6.63	5.21	17.01	5.71	8.44	5.91	5.79	2.44	0	0	29.32
8	8.63	5.8	19.02	6.69	9.29	8.86	5.79	2.44	5.07	0.95	49.6
10	10.75	6.26	22.46	7.68	11.1	8.86	8.19	2.91	7.21	1.65	73.41
12	12.75	6.5	25.39	9.5	12.2	8.86	8.19	2.91	9.96	2.7	89.29

MATERIAL LIST			
NO.	Description	Material	Specification
1	Body	Nylon-11 Coated	ASTM A536
2	Disc	EPDM Encapsulated	ASTM A536
3	Stem	Ductile Iron	ASTM A536
4	Signal & Gearbox	Ductile Iron	AISI410
5	Hand wheel	Ductile Iron	ASTM A536
6	O-ring	EPDM	ASTM A536

PI TAPE INSTRUCTIONS

GROOVE DIAMETER

Make sure the groove and gasket sealing area (A Dim) are clean, smooth and free of any surface imperfections. Wrap a Go-NoGo Pi Tape around the groove, overlapping the tape as shown making sure the tape is in the groove and not twisted. The arrow should be within the **Groove Diameter Range** for the pipe size, if the arrow falls outside this range the groove is out of spec and the grooving tool should be adjusted.



MAXIMUM FLARE DIAMETER

Wrap a Go-NoGo Pi Tape around the end of the pipe as shown, overlapping the tape as shown and making sure that the tape is not twisted. The arrow must fall between the **Pipe OD Range** band and the **Max Flare Line**. The groove is out of spec if the arrow falls outside the **Max Flare Line**.



OD PIPE DIAMETER

Wrap a Go-NoGo Pi Tape around the pipe OD (away from the groove), making sure that the pipe is clean and free of any rust, dirt, welding beads etc, overlapping the tape as shown and making sure that the tape is not twisted. The arrow must fall within the **Pipe OD Range** to be within spec, if the arrow falls outside this range the pipe is out of spec and must be replaced.



GROOVED STEEL PIPE DIMENSIONS

Nominal Pipe Size (in.)	Actual OD (in.)	Pipe OD		Groove Dia. "C"		Max. Allow Flare Dia. (in.)
		Max. (in.)	Min. (in.)	Max. (in.)	Min. (in.)	
3/4	1.050	1.060	1.040	0.938	0.923	1.15
1	1.315	1.328	1.302	1.190	1.175	1.43
1-1/4	1.660	1.676	1.644	1.535	1.520	1.77
1-1/2	1.900	1.919	1.881	1.775	1.760	2.01
2	2.375	2.399	2.351	2.250	2.235	2.48
2-1/2	2.875	2.904	2.846	2.720	2.702	2.98
3	3.500	3.535	3.469	3.344	3.326	3.60
3-1/2	4.000	4.040	3.969	3.834	3.814	4.10
4	4.500	4.540	4.469	4.334	4.314	4.60
5	5.563	5.619	5.532	5.395	5.373	5.66
6	6.625	6.688	6.594	6.455	6.433	6.73
8	8.625	8.688	8.594	8.441	8.416	8.80
10	10.750	10.813	10.719	10.562	10.535	10.92
12	12.750	12.813	12.719	12.531	12.501	12.92

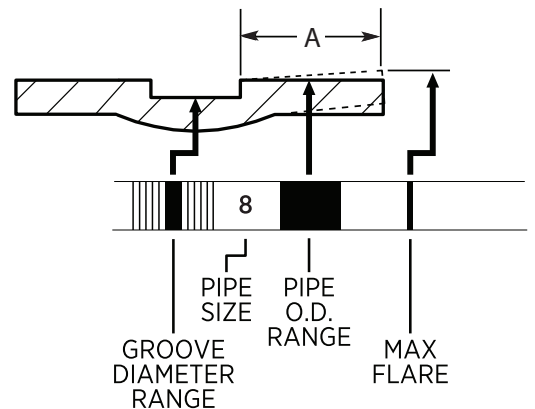

GROOVING SPECIFICATIONS

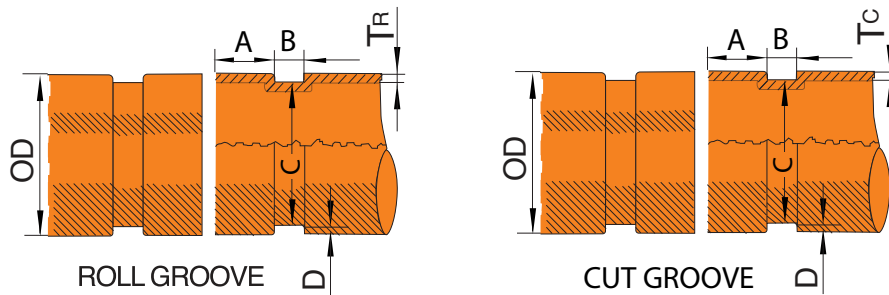

PIPE GROOVING SPECIFICATIONS												
1 Nominal Size (in.)	2 Pipe Outside Diameter OD (in.)			3 Gasket Seat A (in.)	4 Groove Width B (in.)		5 Groove Diameter C (in.)		6 Groove Depth Ref. D (in.)	7 Min. Allowable Wall Thickness (in.)		8 Max. Allowable Flare Diameter (in.)
	Actual Size	Tolerance			Roll Groove	Cut Groove	Actual Size	Toler.		Roll Groove	Cut Groove	
1	1.315	0.013	0.013	0.625	0.281	0.313	1.190	0.015	0.063	0.065	0.133	1.43
1-1/4	1.660	0.016	0.016	0.625	0.281	0.313	1.535	0.015	0.063	0.065	0.140	1.77
1-1/2	1.900	0.019	0.019	0.625	0.281	0.313	1.775	0.015	0.063	0.065	0.145	2.01
2	2.375	0.024	0.024	0.625	0.344	0.313	2.250	0.015	0.063	0.065	0.154	2.48
2-1/2	2.875	0.029	0.029	0.625	0.344	0.313	2.720	0.018	0.078	0.083	0.188	2.98
3	3.500	0.035	0.031	0.625	0.344	0.313	3.344	0.018	0.078	0.083	0.188	3.60
4	4.500	0.045	0.031	0.625	0.344	0.375	4.334	0.020	0.083	0.083	0.203	4.60
4-1/2	5.000	0.050	0.031	0.625	0.344	0.375	4.834	0.020	0.083	0.095	0.203	5.10
5	5.563	0.056	0.031	0.625	0.344	0.375	5.395	0.022	0.084	0.109	0.203	5.66
6	6.625	0.063	0.031	0.625	0.344	0.375	6.455	0.022	0.085	0.109	0.219	6.73
8	8.625	0.063	0.031	0.750	0.469	0.438	8.441	0.025	0.092	0.109	0.238	8.80
10	10.750	0.063	0.031	0.750	0.469	0.500	10.562	0.027	0.094	0.134	0.250	10.92
12	12.750	0.063	0.031	0.750	0.469	0.500	12.531	0.030	0.109	0.156	0.279	12.92

Column 1

Nominal IPS pipe outside diameter.

Column 2

Maximum deviation from square cut ends for 1.25" thru 3" is 0.03"; for 4" thru 6" is 0.045" and for 8" and above is 0.06".

Column 3

To provide a lock tight seal, the gasket seating area on pipe shall be free of roll marks, indentations, paint scale, dirt, chips, grease, rust and etc.

Column 4

Groove width. Groove bottom to be free from loose dirt, chips, rust and scales. Bottom of grooves to be radius and the vertical wall of grooves must provide at least 0.03" vertical side for proper assembly of couplings.

Column 5

Groove outside diameter. The groove must be concentric to the pipe circumference. Groove must be within the diameter tolerance indicated.

Column 6

Groove depth. For reference only. Refer to Column 5.

Column 7

Minimum allowable wall thickness to which the pipemay be roll grooved or cut grooved.

Column 8

Maximum allowable pipe and flare diameter. Measured at the most extreme pipe ends.

RIGID COUPLING STYLE 5 & FLEXIBLE COUPLING STYLE 12 INSTALLATION AND ASSEMBLY INSTRUCTIONS

Step 1. Check & Lubricate Gasket

Apply a thin coating of lubricant to the exterior surface and sealing lips of the EPDM gasket. Be careful that foreign particles do not adhere to lubricated surfaces.



Step 2. Gasket Installation

Slip the gasket over the pipe end making sure the gasket lip does not overhang the pipe end.



Step 3. Alignment

After aligning the two pipe ends, pull the gasket into position centering it between the groove. It should not extend into the groove on either pipe.



Step 4. Housings

Place the coupling housing halves over the gasket making sure the housing keys engage the grooves. Insert the bolts and turn nuts finger tight.

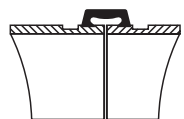

Step 5.

Tighten the nuts alternately and equally until there is a small gap of approximately 1/16 of an inch.

CAUTION: Uneven tightening may cause the gasket to pinch.

NOTE: Flexible couplings should be tightened bolt pad to bolt pad.



Step 6. Assembly is Complete

Visually inspect the pipe joint to assure the coupling keys are fully engaged in the pipe grooves and the bolt pads have equal gaps.



Nuts should be securely tightened but no specific torque specified.

GEMLOCK RIGID COUPLING - ANGLE PATTERN 5A

INSTALLATION INSTRUCTIONS

Step 1. Prior to installation inspect the coupling to insure that the groove is to spec, and then remove any burrs, dents, rust or dirt from around the grooved area. This area must be free from any defects.



Step 2. Apply a non-petroleum, non-toxic lubricant, such as Lansdale's, Lans Lube to the outer and inner ring of the gasket. This will help with assembly and help seat the gasket during pressurization of the system.



Step 3. Slide the gasket over the pipe or fitting end insuring that the gasket is flush with the end of the pipe or fitting. The gasket must not protrude over the edge of the pipe or fitting.



Step 4. Butt the adjoining grooved pipe or fitting up against the gasketed piece and then slide the gasket over this adjoining pipe/fitting until the gasket sits equally on the "A" dimension of both grooves. The gasket should now be in the proper position to insure a proper seal for a leak free joint.



Step 5. Install the coupling one piece at a time, making sure that the coupling keys fit into groove around the circumference of the groove. Install the bolts and nuts and hand tighten.



Step 6. Tighten the nuts evenly by alternating sides until the proper torque values are achieved. There should be pad to pad contact of the bolt pads at this point, with equal and positive or neutral offsets present at each bolt pad, refer to the torque tables below.



WARNING:

1. It is important to tighten the nuts evenly by alternating sides to prevent gasket pinching.
2. Proper torquing of bolts is required to obtain specified performance. Over torquing may result bolts or cast broken. Pipe joint separation may result in significant property damage and serious injury.
Required Assembly Torques

BOLT SIZE	REQUIRED	TORQUE
(in.)	N.M	lbs.-ft.
3/8	40-60	30-45
1/2	110-135	80-100
5/8	135-175	100-130
3/4	175-245	130-180
7/8	245-325	180-240

GEMLOCK ONE-BOLT, PUSH-ON COUPLING STYLE 99 INSTALLATION INSTRUCTIONS

Step 1. Inspect exterior groove and ends of the pipe to verify all burrs, loose debris, dirt, chips, paint and any other foreign material such as grease are removed. Pipe end sealing surfaces must be free from sharp edges, projections, indentations, and/or other defects.

Step 2. Do not remove the nut from the bolt. Open the coupling by extending the coupling segments out to the extent allowed by the bolt and nut.

NOTE: The Gemlock Style 99 coupling, comes with a pre-lubricated EPDM-A gasket and it is recommended that lubricant such as Lansdale's, LansLube, be applied onto the visible portion of the gasket at the bolt pad. Additionally, it is recommended to use a silicon based lubricant in dry pipe and freezer systems.

Step 3. Push the gasket/coupling onto one end of the pipe until the positioning-plate of the gasket is in contact with the end of the pipe (SEE FIGURE 1) the red highlight is the positioning-plate. The pipe end should not cross through the positioning-plate of the gasket. (SEE FIGURE 2).

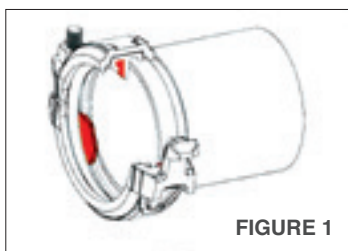

FIGURE 1

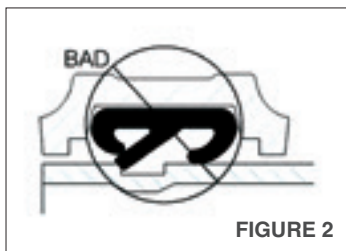

FIGURE 2

Step 4. Slide the other pipe end into the gasket/coupling ensuring that it makes contact with the positioning-plate of the gasket. Both pipes should be aligned vertically and horizontally. Verify that the housing is over the gasket and that the housing keys are aligned with the pipe grooves.

Step 5. Tighten nut to the recommended bolt torque. (SEE NOTE BELOW)
Visually inspect the coupling to ensure that the housing keys are engaged into the pipe grooves.

SIZE (In.)	SPECIFIED BOLT TORQUE
1-2	60-75 ft-lbs.
2-1/2	65-80 ft-lbs.
3	80-95 ft-lbs.
4	90-115 ft-lbs.
5-6	100-120 ft-lbs.

CORRECT



INCORRECT



NOTE:

When fully tightened a small gap of approximately 1/16" should exist between the bolt pads. Bolt-torque information is supplied as a guideline and may be used when setting the torque on power impact wrenches. Refer to the manufacturer's instructions for settings. Bolt lengths require the use of deep sockets.

CAUTION:

Removal of the nut from the bolt may result in the coupling segments separating at the hinges and the coupling disengaging from the pipe. Use caution to avoid equipment damage and/or personal injury. Do not leave coupling unattended on a single pipe end as it may disengage from the pipe. Failure to do so may result in equipment damage and/or personal injury.

For the latest installation instructions, scan the QR code to watch the Gemlock 99 Grooved Coupling Installation video.



Step 1.



Step 2.



Lubricate here

Step 3.



Step 4.



Step 5.



GEMLOCK 2-BOLT ANGLE PATTERN, PUSH-ON COUPLING STYLE 99-2 INSTALLATION INSTRUCTIONS

Step 1. Inspect exterior groove and ends of the pipe to verify all burrs, loose debris, dirt, chips, paint and any other foreign material such as grease are removed. Pipe end sealing surfaces must be free from sharp edges, projections, indentations, and/or other defects.

Step 2. Do not remove the nut from the bolt. Open the coupling by extending the coupling segments out to the extent allowed by the bolt and nut.

NOTE: The Gemlock Style 99-2 coupling, comes with a pre-lubricated EPDM gasket and it is recommended that lubricant such as Lansdale's, LansLube, be applied onto the visible portion of the gasket at the bolt pad. Additionally, it is recommended to use a silicon based lubricant in dry pipe and freezer systems.

Step 3. Push the gasket/coupling onto one end of the pipe until the positioning-plate of the gasket is in contact with the end of the pipe. The pipe end should not cross through the positioning-plate of the gasket. (SEE FIGURE 1).

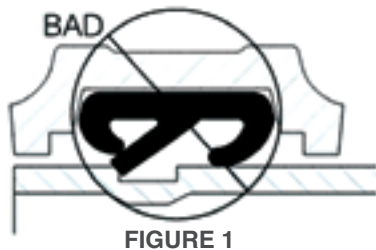

RECOMMENDED TORQUES

PRODUCT SIZE (In.)	MIN. - MAX TORQUE
1	26–37 ft-lbs
1-1/4	26–37 ft-lbs
1-1/2	26–37 ft-lbs
2	26–37 ft-lbs
2-1/2	26–37 ft-lbs
3	26–37 ft-lbs
4	55–80 ft-lbs
5	55–80 ft-lbs
6	55–80 ft-lbs
8	90–120 ft-lbs

Step 4. Slide the other pipe end into the gasket/coupling ensuring that it makes contact with the positioning-plate of the gasket. Both pipes should be aligned vertically and horizontally. Verify that the housing is over the gasket and that the housing keys are aligned with the pipe grooves. Visually inspect the coupling to ensure that the housing keys are engaged into the pipe grooves.

Step 5. Tighten the nuts evenly by alternating sides until the specified torque value are achieved. For angle pad coupling, tighten the nuts evenly until a pad to pad contact is achieved. Equal and positive or neutral offsets shall be present at each bolt pad location. Tighten nut to the recommended bolt torque. Visually inspect the coupling to ensure that the housing keys are engaged into the pipe grooves.

NOTE: Bolt-torque information is supplied as a guideline and may be used when setting the torque on power impact wrenches.

CAUTION:

Removal of the nut from the bolt may result in the coupling segments separating at the hinges and the coupling disengaging from the pipe. Use caution to avoid equipment damage and/or personal injury. Do not leave coupling unattended on a single pipe end as it may disengage from the pipe. Failure to do so may result in equipment damage and/or personal injury.

For the latest installation instructions, scan the QR code to watch the Gemlock 99-2 Grooved Coupling Installation video.



Gemlock 99-2 Installation Video

Step 1.



Step 2.

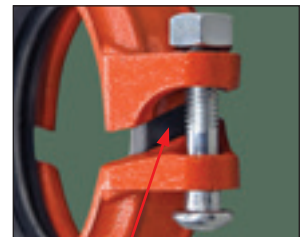

Lubricate here

Step 3.



Step 4.



Step 5.



GEMLOCK GROOVED FLANGE STYLE 14 INSTALLATION INSTRUCTIONS

When assembling the Gemlock Grooved Flange always use Lansdale Lanslube lubricant for proper assembly, the ID of the gasket should be lubricated for ease of placement onto the pipe, and all external surfaces should be lubricated to prevent pinching of the gasket during installation. Before the assembly process begins the grooved end of the pipe must be inspected to insure that the grooved dimensions are correct and the pipe end and "A" dimension are free of any burrs and indentations that would interfere with the sealing of the flange gasket and create a leak path.

Step 1. After inspecting the pipe end, lubricate the ID of the gasket and install the gasket onto the "A" dimension of the pipe; making sure that the actual groove is clear from any gasket material.



Step 2. Lubricate the OD of the gasket before assembling the flange housing. Remove one of the side bolts and loosen the other (it may be necessary to remove both side bolts) and slide the housing into place, as shown above, making sure it fully engages the groove. Replace the side bolts and tighten alternately and evenly until they are tight, being careful not to pinch the gasket, until the flange housing bolt holes line up. Bolt torques for the side bolts are as follows:



- 3/8" - 30-45 Ft-lbs
- 1/2" - 80-100 Ft-lbs
- 5/8" - 100-130 Ft-lbs
- 3/4" - 130-180 Ft-lbs

Step 3. Prior to the assembly of the flange to the grooved flange adapter, check to make sure that the flange adapter keys are fully engaged into the groove, around the full circumference of the pipe. Inspect the assembled flange adapter, making sure that it is square to the pipe and properly aligned, prior to final assembly lubricate the exposed gasket (as shown) that will mate up to the flange and create the sealing surface.



Step 4. Final Assembly. Before assembling the mating flange, it should be inspected to insure it is flat and free of any imperfections that would interfere with the sealing surface. Line up the bolt holes of the grooved flange and the mating flange and then bring the flanges together, (do not rotate the mating flange to line up the bolt holes when it is in contact with the grooved flange). Install the flange bolting and tighten evenly and alternately in a star pattern until they reach the specified torque, as follows:



- 5/8" - 110-140 Ft-lbs
- 3/4" - 220-250 Ft-lbs
- 7/8" - 320-400 Ft-lbs
- 1" - 360 - 460 Ft-lbs

PLEASE NOTE:

The use of an impact gun is not recommended. The use of a flange adapter insert is required if the grooved flange is mating up to any type of non-metallic surface.

GEMLOCK MECHANICAL TEE INSTALLATION INSTRUCTIONS

Step 1. Make sure the correct hole saw size is being used. Holes must not be drilled on the weld of the pipe. Ensure that 5/8 inch area around the hole is clean, remove any burrs, rust, grease or dirt.



Step 2. Inspect the sealing surface of the gasket to make sure no debris is present. Lubricate the exposed sealing surface of the gasket, with Lanslube.



Step 3. Put gasket in the Mechanical Tee making sure the gasket lines up with the tab recesses in the housing.



Step 4. Install the Mechanical Tee in the hole, making sure it is centered.



Step 5. Install the bottom piece and make sure the locating collar engages the outlet hole properly. Check this engagement by rocking the upper (outlet) housing in the hole. Tighten nuts by hand to hold the MT in place.



Step 6. Tighten the nut evenly by alternating sides until the specified torque values are achieved.



WARNING:

1. It is important to tighten the nuts evenly by alternating sides to prevent gasket pinching.
2. Proper torquing of bolts is required to obtain specified performance. Over torquing may result in bolts or cast breaking.

BOLT SIZE (in.)	WEIGHT lbs.-ft.
3/8	30-45
1/2	80-100
5/8	100-130
3/4	130-180
7/8	180-240

GASKET DATA STANDARD IPS GASKETS

GRADE	E			
TEMPERATURE RANGE	-40°F TO +230° F -40°C to + 110° C			
COMPOUND	EPDM CONFORMING TO ASTM D2000 (2CA615A25B24F17Z)			
GENERAL SERVICE RECOMMENDATIONS	Recommended for hot water service within the specified temperature range plus a variety of dilute acids, oil-free air and many chemical services. Optional EPDM Gasket approved to ANSI/NSF 61 cold +73°F (+23°C) and hot +180°F (+82°C) for potable water service is available on request. Not recommended for petroleum services.			
Acetaidehyde Acetic Acid up to 10% 100°F (38°C) Acetic Anhydride Acetone Acetophenone Acetylene Alkalis Allyl Alcohol to 96% Aums Aluminum Chloride Aluminum Fluoride Aluminum Hydroxide Aluminum Nitrate Aluminum Phosphate Aluminum Salts Aluminum Sulfate Ammonia Gas, Cold Ammonia Gas, Hot Ammonia, Liquid Ammonium Carbonate Ammonium Fluoride Ammonium Hydroxide Ammonium Metaphosphate Ammonium Nitrate Ammonium Persulfate to10% Ammonium Sulfate Ammonium Sulfide Ammonium Thictrnate Ammonium Thiyoanate Amyl Acetate Amyl Alcohol Aniline Aniline Dyes Aniline Hydrochloride Aniline Oil Antimony Chloride Antimony Trichloride Argon Gas Barium Carbonate Barium Chloride Barium Hydroxide Benzaldehyde Benzoic Acid Benzyl Alcohol Benzyl Benzoate Bleach, 12% Active CP Borax	Bordeaux Mixture Boric Acid Butanol (see Butyl Alcohol) Butyl Acetate Butyl Acetyl Ricinoleate Butyl Alcohol Butyl "Cellosolve Adipate" Butyl Phenol Butylene Glycol Calcium Chloride Calcium Hydroxide (Lime) Calcium Hypochlorite Calcium Hypochlorite Calcium Hypochloride Calcium Nitrate Calcium Sulfide Carbotal Carbon Dioxide, Dry Carbon Dioxide, Wet Carbon Monoxide Caustic Potash, Cellosolve Acetate Cellosolve (Alcohol Ether) Cellulube 220 (Tri-Aryl-Phosphate) Cellulube Hydraulic Fluids Chloric Acid to 20% Chlorine, Water Chloroacetic Acid Chloroacetone Citric Acid Copper Flouride Copper Nitrate Copper Sulfate Cyclohexanone Deionized Water Dibutyl Phialate Diethyl Sewbacate Diethylene Glycol Dioctyl Phthalate Diozne Dowtherm SR-1 Ethanolamine Ethyl Acetoacetate	Ethyl Alcohol Ethyl Cellulose Ethyl "Cellusolve" Ethyl Chloride Ethyl Oxalate Ethylene Chlorohydrin Ethylene Glycol Ferric Chloride to 35% Ferric Chloride, Saturated Ferric Hydroxide Fluboric Acid Fly Ash Foam Formaldehyde Formic Acid Freon 134a, 176°F (80°C) Fumaric Acid Furfuryl Alcohol Glue Glycerin Glycerol Glycol Glycolic Acid Halon Hexaldehyde Hydrobromic Acid to 40% Hydrochloric Acid to 36% 75°F (28.9°C) Hydrocyamic Acid Hydrogen Gas, Cold Hydrogen Gas, Hot Hydrogen Sulfide, Hydroxylamine Sulfate, Hydrochlorous Acid, Dilute Isobutyl Alcohol Isopropyl Acetate Isopropyl Alcohol Ketones Lead Chloride Lime and H2O Magnesium Chloride Magnesium Hydroxide Magnesium Sulfate Mercuric Chloride	Mercuric Cynaide Mercury Methyl Acetate Methl Alcohol, Methanol Methyl Cellosolve (Ether) Methyl Ethyl Ketone Methl Formate Methyl Isobutyl Carbionol Methyl Isobutyl Ketone Nickel Chloride Nickel Nitrate Nickel Plating Solution 125°F (52°C)-Max. Nitric Acid, to 10%, 75°F-(24°C)-Max. Nitric Acid, to 10%, 75°F- (24°C)-Max. Nitrous Oxide Oxalic Acid Ozone Phosphate Ester Phosphoric Acid to 75% & 70° F (21°C)-Max Potassium Bromide Potassium Carbonate Potassium Chloride Plating Solutions (gold, brass, cadmium, copper, lead, silver tin, zinc) Potassium Cyanide Potassium Ferricyanide Potassium Ferrocyanide Potassium Iodide Potassium Nitrate Potassium Permanganate, saturated to 25% Potassium Sulphate Propanol Propyl Alcohol Propylene Glycol Proguard 55 Pyrrole Salicylic Acid Silver Cyanide Silver Nitrate Skydrol 500 Phosphate Ester Soda Ash, -Sodium Carbonate	Sodium Bicarbonate Sodium Bisulphate Sodium Bisulphite (black liquor) Sodium Bromide Sodium Chlorate Sodium Chloride Sodium Cynaide Sodium Hydroxide, to 50% Sodium Hypochlorite, to 20% Sodium Metaphosphate Sodium Nitrate Sodium Peroxide Sodium Phosphate Sodium Silicate Sodium Suphide Sodium Sulphite Solution, to 20% Sodium Thiosulphate, "Hypo" Stannous Chloride, to 15% Starch Sulphur Sulphuric Acid, to 25%, 150°F (66°C)-Max. Tributyl Phosphate Triethanolamine Trisodium Phosphate Urea Vinyl Acetate White Liquor Zinc Sulphate



FIRE PROTECTION PRODUCTS CROSS REFERENCE CHART

PRODUCT	GEMLOCK®	VICTAULIC®	GRUVLOK®	ANVIL STAR® (SPF)	TYCO®
Rigid Coupling	5	—	7400	C-4	577
Rigid One-Bolt Push-On Coupling	99	009, 109	74 FP	—	579
Rigid Coupling - Angle Pattern	5A	005	—	—	—
Light Flexible Coupling	12	75	7000	C-3	705
Reduced Coupling	25	750	7010	RC-2	716
Groove Split Flange	14	744	7012	F-3	71
Flange Adapter Nipple	F190	41	7788	F-2	341
Mechanical Tee with Grooved Outlet	15,35	920	7046	MT-2, MT-2A	730
Mechanical Tee with Threaded Outlet	16, 36	920	7045	MT-1, MT-1A	730
Tee Lock	13	922	—	MT-30	522
Short Pattern 90° Elbow	F105	001	7450	SE-1	510S
Short Pattern 45° Elbow	F106	003	7051	E-2	501
Short Pattern Straight Tee	F107	002	7460	ST-1	519S
Short Pattern Reducing Tee	115	25	7061	T-2	221
Short Pattern Cross	F135	35	7068	X-1	327
Standard 90° Elbow	100	10	7050	E-1	510
Standard 22-1/2° Elbow	102	12	7052	E-3	212, 312, 512
Standard 11-1/4° Elbow	103	13	7053	E-4	211, 311, 511
Standard Tee	110	20	7060	T-1	516
Standard Cap	150	006	7074	K-1	260
Concentric Reducer	140	50	7072	R-1	250, 550
Eccentric Reducer	145	51	7073	R-2	—
Drain Elbow	F105D	10DR	7050DR	E-9	510DE
Drain Cap	F155D	—	—	K-9	—
Adapter Reducing Elbow 90° GRV x THD	105TL	67	SE-5	—	6

Victaulic® - Registered Trademark of Victaulic Company of America.

Gruvlok® - Registered Trademark of ASC Engineered Solutions™.

AnvilStar® - Registered Trademark of ASC Engineered Solutions™



TERMS: NET 30 DAYS

This Limited Warranty protects the Buyer from manufacturer defects in all products sold by GemLock (“Company”) to Buyer (“Covered Products”) for a period of one (1) year from delivery of the Covered Products to Buyer or to a location specified by Buyer (the “Warranty Period”).

During the Warranty Period, Company will repair or replace (at Company’s soleoption) any Covered Products at no charge if after evaluation such Covered Products are deemed by Company to be of defective manufacture and unusable for ordinary purposes. This shall be Buyer’s sole remedy for defects.

This Limited Warranty applies only to manufacturer defect in Covered Products used under normal operation, and does not cover defects caused in whole or part by installation, project design or any other external factors. Any misuse, abuse, or unauthorized repair or modification of or affecting the Covered Products, or failure to follow manufacturer instructions or recommendations, shall void this Limited Warranty.

UNLESS SPECIFICALLY NEGOTIATED IN A SEPARATE WRITING, COMPANY OFFERS NO OTHER WARRANTIES, EXPRESS OR IMPLIED, INCLUDING THE IMPLIED WARRANTIES OF MERCHANTABILITY OR OF FITNESS FOR A PARTICULAR PURPOSE. In no event shall Company be responsible for any special, punitive, incidental, consequential or indirect damages of any kind, damages exceeding the price of any defective Covered Products, or any removal or reinstallation costs.

To obtain warranty service, Buyer must contact Company within ten (10) days of when it becomes aware of a warranty issue, but in no event later than three hundred seventy five (375) days from delivery of the Covered Products to Buyer. This Limited Warranty is transferable only with written consent of Company.

 GemLock®

GROOVED PRODUCTS

www.gemlockgrooved.com